

User's Guide
Model 24C
Cryogenic Temperature Controller

Physike Technology Co.,Ltd
First floor,Building 19,Guanghua Pioneer
Park,No.18 Anningzhuang East Road,Haidian
District,Beijing,China
Phone:+86-10-62166302/82367826
Email:sales@physike.com
Website:www.physike.com

©Copyright 2010- 2020
Cryogenic Control Systems, Inc.
All Rights Reserved.

Printing History

Edition 5h. May, 2021

Certification

Cryogenic Control Systems, Inc. (Cryo-con) certifies that this product met its published specifications at the time of shipment. Cryo-con further certifies that its calibration measurements are traceable to the United States National Institute of Standards and Technology (NIST).

Warranty

This product is warranted against defects in materials and workmanship for a period of one year from date of shipment. During this period Cryo-con will, at its option, either repair or replace products which prove to be defective.

For products returned to Cryo-con for warranty service, the Buyer shall prepay shipping charges and Cryo-con shall pay shipping charges to return the product to the Buyer.

However, the Buyer shall pay all shipping charges, duties, and taxes for products returned to Cryo-con from another country.

Warranty Service

For warranty service or repair, this product must be returned to a service facility designated by Cryo-con.

Limitation of Warranty

The foregoing warranty shall not apply to defects resulting from improper or inadequate maintenance by the Buyer, Buyer supplied products or interfacing, unauthorized modification or misuse, operation outside of the environmental specifications for the product, or improper site preparation or maintenance.

The design and implementation of any circuit on this product is the sole responsibility of the Buyer. Cryo-con does not warrant the Buyer's circuitry or malfunctions of this product that result from the Buyer's circuitry.

In addition Cryo-con does not warrant any damage that occurs as a result of the Buyer's circuit or any defects that result from Buyer-supplied products.

Notice

Information contained in this document is subject to change without notice.

Cryo-con makes no warranty of any kind with regard to this material, including, but not limited to, the implied warranties of merchantability and fitness for a particular purpose.

Cryo-con shall not be liable for errors contained herein or for incidental or consequential damages in connection with the furnishing, performance, or use of this material. No part of this document may be photocopied, reproduced, electronically transferred, or translated to another language without prior written consent.

Trademark Acknowledgement

CalGen® and Cryo-Con® are registered trademarks of Cryogenic Control Systems, Inc. All other product and company names are trademarks or trade names of their respective companies.

Safety

The Model 24C does not contain any user serviceable parts. Do not open the enclosure. Do not install substitute parts or perform any unauthorized modification to the product. For service or repair, return the product to Cryo-con or an authorized service center.

Table of Contents

Introduction.....	1
Sensor Inputs.....	1
Control Loops.....	2
Remote Interfaces.....	2
Preparing the controller for use.....	3
Supplied Items.....	3
Verify the AC Power Line Voltage Selection.....	3
Apply Power to the Controller.....	3
Installation.....	4
Specifications, Features and Functions.....	9
User Interface.....	9
Input Channels.....	9
Control Loop Outputs.....	13
General.....	17
Front Panel Operation.....	19
The Keypad.....	19
The Front Panel Display.....	23
Instrument Setup Menus.....	26
Basic Setup and Operation.....	43
Selecting a Sensor.....	43
Using NTC Sensors (Type: ACR).....	44
Using PTC resistor sensors.....	46
Using the Relays.....	47
Installing Custom Sensor Calibration Curves.....	49
Downloading a PID table.....	52
Autotuning.....	54
Temperature Ramping.....	59
Using Temperature Alarms.....	62
Using the Non-powered Control Loops.....	63
Using CalGen.....	64
Using Thermocouple Sensors (Type TC70).....	67
Restoring Factory Defaults.....	70
Shielding and Grounding.....	71
Instrument Calibration.....	73
Cryo-con Calibration Services.....	73
Calibration Interval.....	73
Remote Operation.....	74
Remote Interface Configuration.....	74
Remote Programming Guide.....	77
General Overview.....	77
An Introduction to the SCPI Language.....	78
Remote Command Tree.....	87
Remote Command Descriptions.....	91
EU Declaration of Conformity.....	109

Appendix A: Installed Sensor Curves.....	111
Factory Installed Curves.....	111
User Installed Sensor Curves.....	112
Sensor Curves on CD.....	113
Sensor Calibration Curve File Format.....	114
Appendix B: Updating Instrument Firmware.....	117
Discussion.....	117
Updating unit firmware.....	118
Appendix C: Troubleshooting Guide.....	121
Error Displays.....	121
Control Loop and Heater Problems.....	122
Temperature Measurement Errors.....	123
Remote I/O problems.....	124
General problems.....	126
Appendix D: Tuning Control Loops.....	127
Introduction.....	127
Various methods for obtaining PID coefficients.....	127
Manual Tuning Procedures.....	128
Appendix E: Sensor Data.....	129
Cryo-con S700 Silicon Diode.....	129
Cryo-con S900 Silicon Diode.....	130
Cryo-con S950 Silicon Diode.....	131
Sensor Packages.....	132
Appendix F: Configuration Scripts.....	135
Script File Structure.....	135
Appendix G: Sensor Data Tables.....	139
Silicon Diode.....	139
Platinum RTD.....	141
Rhodium-Iron.....	141
Cryogenic Linear Temperature Sensor (CLTS).....	141
Cernox™.....	142
Ruthenium-Oxide.....	144
Appendix H: Rear Panel Connections.....	147
AC Power Connection.....	147
Fuse Replacement and Voltage Selection.....	148
Sensor Connections.....	149
Control Loop #1 Connections.....	151
Control Loop #2 and Relay Connections.....	151
Ethernet (LAN) Connection.....	152
IEEE-488.2 Connections.....	152
RS-232 Connections.....	152
Index.....	153

Index of Figures

Figure 1: 4122-030 Rack Mount Kit.....	4
Figure 2: Model 24C Front Panel Layout.....	19
Figure 3: Thermocouple Module.....	67
Figure 4: Thermocouple Switches.....	67
Figure 5: Model 24C Rear Panel Layout.....	147
Figure 6: Proper Assembly of the Input Connector.....	149
Figure 7: Diode and Resistor Sensor Connections.....	150

Index of Tables

Table 1: Hardware Revision Levels.....	6
Table 2: Model 24C Instrument Accessories.....	7
Table 3: Cryogenic Accessories.....	8
Table 4: Supported Sensor Configurations.....	9
Table 5: Accuracy and Resolution for PTC Resistors.....	10
Table 6: Minimum and Maximum Resistance vs. Bias Voltage.....	11
Table 7: Accuracy and Resolution of NTC Resistors.....	11
Table 8: Control Type Summary.....	13
Table 9: Loop #1 Heater output ranges.....	14
Table 10: Loop #2 Heater output ranges.....	15
Table 11: Control Loop Status Indications.....	16
Table 12: Keypad key functions.....	22
Table 13: Temperature Units.....	24
Table 14: Input Channel Configuration Menu.....	27
Table 15: Control Loop Setup Menus.....	29
Table 16: User Configurations Menu.....	32
Table 17: System Configuration Menu.....	33
Table 18: Over Temperature Disconnect Configuration.....	35
Table 19: Network Configuration Menu.....	37
Table 20: PID Table Edit Menu.....	39
Table 21: Sensor Setup Menu.....	40
Table 22: Calibration Curve Menu.....	41
Table 23: Relay Modes.....	47
Table 24: Relay Status Indicators.....	47
Table 25: Recommended Sensor Configuration Data.....	50
Table 26: Autotune Menu.....	57
Table 27: Autotune States.....	58
Table 28: Alarm Status Indicators.....	62
Table 29: First CalGen Menu, Diode Sensor.....	65
Table 30: CalGen Menu, 2-point Diode Sensor.....	65
Table 31: CalGen New Curve Menu.....	66
Table 32: Thermocouple Polarities.....	69
Table 33: GPIB Host Setup Parameters.....	75
Table 34: Loop #1 Ranges.....	99
Table 35: Loop #2 Ranges.....	99
Table 36: BB Package Specifications.....	133
Table 37: Cable Color Code.....	133
Table 38: AC Power Line Fuses.....	148
Table 39: Input Connector Pin-out.....	149
Table 40: Sensor Cable Color Codes.....	150
Table 41: Loop 1 Connections.....	151
Table 42: Loop #2, #3, #4 and Relay Connections.....	151
Table 43: RS-232 DB-9 Connector Pinout.....	152

Introduction

The Model 24C is a four-input, four-control loop cryogenic temperature controller designed for general purpose laboratory and industrial use. Each input is independent and capable of temperature measurement to <100mK with an appropriate temperature sensor. The Model 24C supports virtually any cryogenic temperature sensor produced by any manufacturer.

The four-output control loop circuits feature a primary 50W heater, a secondary heater of 25W and two 10/5-Volt non-powered outputs. All control modes are supported by all outputs.

The 24C front panel incorporates a large high resolution graphics TFT type Liquid Crystal Display with an exceptionally wide viewing angle. With it's bright white LED back-light, complete instrument status can be seen at a glance, even from across the room.

Sensor Inputs

The Model 24C has four identical input channels, each of which implements a ratiometric AC resistance bridge. This bridge uses separate, balanced circuits to simultaneously measure both the voltage drop across the temperature sensor and the current flowing through it. By measuring current with a higher accuracy than it can be set, precision resistance measurements are obtained, even at low excitation levels.

Negative-Temperature-Coefficient (NTC) resistors are often used as low temperature thermometers, especially at ultra-low temperature. Examples include Ruthenium-oxide, Carbon-Glass, Cernox™, Carbon-Ceramic, Germanium and various thermistors.

The Model 24C provides robust support for NTC resistor sensors by using continuously variable constant-voltage AC excitation.

Positive Temperature Coefficient (PTC) resistor sensors including Platinum, CLTS and Rhodium-Iron RTDs use the resistance bridge in a constant-current, AC mode. Platinum RTD sensors use a built-in DIN standard calibration curve that has been extended to 14K for cryogenic use.

Silicon diode sensors are supported over their full temperature range by using the bridge in a DC, constant-current mode.

Thermocouple sensors are supported by using an optional thermocouple module that plugs into any of the Model 24C's input channels. Up to four modules can be connected to a single instrument.

Sensor Curves: The Model 24C includes built-in sensor curves that support most available cryogenic temperature sensors. Additionally, eight **user calibration curves** are available for custom or calibrated sensors. Each user curve may have up to 200 entries and are entered from the front panel, or transferred via any of the available remote interfaces.

New calibration curves may be generated using the CalGen® feature to fit any existing calibration curve at up to three user specified temperature points. This provides an easy and effective method for obtaining higher accuracy temperature measurements without expensive sensor calibrations.

Data logging is performed by continuously recording to an internal 1,365 entry circular buffer. Data is time stamped so that the actual time of an event can be determined. Non-volatile memory is used so that data will survive a power failure.

Input Channel Statistics: The Model 24C continuously tracks temperature history independently on each input channel and provides a statistical summary that indicates the channel's minimum, maximum, average and standard deviation. Also shown are the slope and the offset of the best-fit straight line of temperature history data.

Alarms: Visual, remote and audible alarms are independently programmed to assert, or clear based on high or low temperature condition, or a detected sensor fault. Latched alarms are asserted on an alarm condition and will remain asserted until cleared by the user.

Relays: The Model 24C has two 10-Ampere dry-contact relays. These can be used to control external equipment or implement a fail-safe function.

Control Loops

The Model 24C has four independent control loop outputs:

1. Loop #1 heater output is a linear, low noise RFI filtered current source that can output up to 50 Watts. Three full-scale ranges are available.
2. Loop #2 is a linear heater with two output ranges of 25-Watts and 2.5-Watt full-scale.
3. Loop #3 and #4 are a non-powered analog voltage output intended to control an external booster power supply. Output is selectable at 10 or 5 Volts full scale.

Remote Interfaces

Standard Remote Interfaces include Ethernet and RS-232. IEEE-488.2(GPIB) optional.

The Model 24C's remote command language is SCPI compliant according to the IEEE-488.2 specification. SCPI establishes a common language and syntax across various types of instruments. It is easy to learn and easy to read.

The SCPI command language is identical across all Cryo-con products so that the user's investment in system software is always protected.

Ethernet: 100/10Base-T, electrically isolated.

RS-232 Serial Port: Rates are 9600 to 115,200 Baud. Not electrically isolated.

IEEE-488 (GPIB): External option. IEEE-488.2 compliant. Electrically isolated.

Compatibility: National Instruments LabView™ drivers available for all interfaces.

Preparing the controller for use

The following steps help you verify that the controller is ready for use.

Supplied Items

Confirm that you have received the following items with your controller.

- Model 24C Cryogenic Temperature Controller.
- User's Manualr USB driver AC Power Cordr L-shaped mounting plate.
- Input connector kit (4024-016) consisting of four screw-in DIN-6 input connectors (PN 04-0414).
- Output connector kit (4124-018) consisting of a 10-pin detachable terminal block (04-0007) and a dual banana plug(04-0433).
- Certificate of Conformity.

Verify the AC Power Line Voltage Selection

The AC power line voltage is set to the proper value for your country when the controller is shipped from the factory. Change the voltage setting if it is not correct. The settings are: 100, 120 230, or 240 VAC.

Note: For 235VAC operation, use the 240 VAC setting.

On the rear panel of the instrument, the AC voltage selection is on the power entry module. If the setting is incorrect, please refer to section [Fuse Replacement and Voltage Selection](#) to change it.

Apply Power to the Controller

Connect the power cord and turn the controller on by pressing the **Power** key for a minimum of 2 Seconds. The front panel will show a Power Up display with the model number and firmware revision.

While the Power Up display is shown, the controller is performing a self-test procedure. If an error is detected during this process, the controller will freeze operation with an error message display. If an error is detected during this process, the controller will freeze operation with an error message display. In this case, turn the unit off and refer to [Appendix C: Troubleshooting Guide](#).



Caution: Do not remove the instrument's cover or attempt to repair the controller. There are no user serviceable parts, jumpers or switches inside the unit. Further, there are no software ROM chips, trim pots, batteries or battery-backed memories. All firmware installation and instrument calibration functions are performed externally via the remote interfaces.

After about fifteen seconds, the self-test will complete and the controller will begin normal operation.

Installation

General

The Model 24C can be used as a bench top instrument, or mounted in an equipment rack. In either case, it is important to ensure that adequate ventilation is provided.

It is important to allow at least $\frac{1}{2}$ " of clearance on the left and right sides and to ensure that the exhaust path of the fan is not blocked.

Rack Mounting

You can rack mount the controller in a standard 19-inch rack cabinet using the optional rack mount kit. Instructions and mounting hardware are included with the kit.

4122-030 Single instrument 2U rack mount kit.

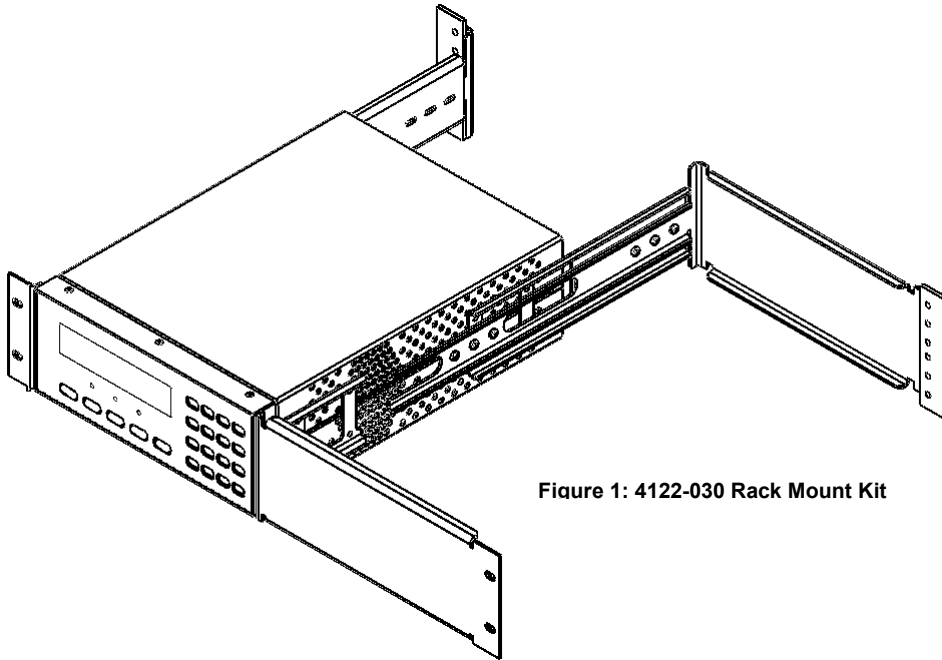

Figure 1: 4122-030 Rack Mount Kit

Ordering Information

Standard	Description
Model 24C	Controller with four standard multi-function sensor input channels.
	<p>Controller includes: User's Manual ,USB drive,four input connectors,detachable power cord and a Certificate of Conformity. Specify AC Line Voltage when ordering:</p> <p>-100 Configured for 90 - 100VAC with detachable USA power cord.</p> <p>-110 Configured for 110 - 120VAC with detachable USA power cord.</p> <p>-220 Configured for 220VAC with detachable universal Euro (Shuko) line cord.</p> <p>-240 Configured for 240VAC with detachable universal Euro (Shuko) line cord.</p>

Options	Description
4039-004	Thermocouple Input Module. Field installable. Supports all thermocouple types. Controller supports up to 4 modules.
4001-002	IEEE-488.2 (GPIB) Option. Field installable.

Technical Assistance

Troubleshooting guides and user's manuals are available on our web page at <http://www.cryocon.com>.

Technical assistance may be also be obtained by contacting Physike as follows:

Physike Technology Co.,Ltd
 First floor,Building 19,Guanghua Pioneer Park,No.18
 Anningzhuang East Road,Haidian District,Beijing,China
 Phone:+86-10-62166302/82367826
 Email:sales@physike.com
 Website:www.physike.com

For updates to LabView™ drivers, Cryo-con utility software and product documentation, go to our web site and select the Download area.

Current Firmware Revision Level

As of May 2020 the firmware revision level for the Model 24C series is 3.37.

Current Hardware Revision Level

As of May 2020, the hardware revision level for the Model 24C series is H.

Hardware Revision	A	B,C,D	F,G,H
Relay contact rating	2.0A, 30W	10.0A, 150W	10.0A, 150W
Non-powered outputs	10.0V	Selectable 10V or 5V full scale.	Selectable 10V or 5V full scale.
Loop 2 output	10W or 1.0W full-scale	25W or 2.5W full-scale	25W or 2.5W full-scale
Vbias Ranges	10mV, 3mV, 1mV, 300uV	10mV, 3mV, 1mV, 300uV	10mV, 3mV, 1mV, 300uV, 200uV and 100uV
Excitation Ranges	1mA, 100uA, 10uA	1mA, 100uA, 10uA	1mA, 100uA, 10uA, 1.0uA
GPIB	Internal	Internal	External Option

Table 1: Hardware Revision Levels

Returning Equipment

If an instrument must be returned to Physike for repair or re-calibration, a Return Material Authorization (RMA) number must first be obtained from the factory. This may be done by Telephone, FAX or e-mail.

When requesting an RMA, please provide the following information:

1. Instrument model and serial number.
2. User contact information.
3. Return shipping address.
4. If the return is for service, please provide a description of the malfunction.

If possible, the original packing material should be retained for reshipment. If not available, consult factory for packing assistance.

Physike's shipping address is:

Physike Technology Co.,Ltd
 First floor,Building 19,Guanghua Pioneer
 Park,No.18 Anningzhuang East Road,Haidian
 District,Beijing,China

Instrument Accessories

Cryo-con Part #	Description
04-0310	AC Power Cord. North American
04-0317	AC Power Cord, Cont. European (Shuko)
04-0414	Din-6 Sensor Input Connector, Amphenol T3400 001
04-0007	Ten-pin detachable terminal block for Loop 2 and relay connections.
04-0433	Dual banana plug for Loop 1 connection.
4042-040	8' Sensor cable, four wire, wired to DIN-6 connector.

Table 2: Model 24C Instrument Accessories

Cryogenic Accessories

Cryo-con Part #	Description
S950	S950 series Silicon diode Temperature Sensors. Temperature range: 1.4 to 400K
CP-100	CP-100 series Ceramic Wound RTD, 100 Ω
GP-100	GP-100 series Glass Wound RTD, 100 Ω
XP-100	XP-100 series Thin Film Platinum RTD, 100 Ω
XP-1K	XP-1K series Thin Film Platinum RTD, 1,000 Ω
3039-002	Cartridge Heater, Silicon free, 25 Ω / 25 Watt, 1/4" x 1 1/8". Temperature range to 1,600K
3039-001	Cartridge Heater, Silicon free, 50 Ω / 50 Watt, 1/4" x 1 1/8". Temperature range to 1,600K
4039-011	Pre-cut Nichrome wire heater w/connectors, 25 Ω
4039-012	Pre-cut Nichrome wire heater w/connectors, 50 Ω
3039-006	Bulk Nichrome Heater Wire, 32AWG, Polyamide insulation, 100'

Table 3: Cryogenic Accessories

Specifications, Features and Functions

User Interface

Display Type: 40 character by 8 line TFT LCD with LED backlight.

Keypad: 23 key Silicon Rubber.

Temperature Display: Seven significant digits, autoranged.

Display Update Rate: 0.5 Seconds.

Display Units: K, C, F or native sensor units.

Input Channels

There are four input channels, each of which may be independently configured for any of the supported sensor types.

Sensor Connection: 4-wire differential. Screw-in type DIN-6 circular.

Connections are described in the [Sensor Connections](#) section.

Ambient Temperature: 25°C ± 5°C for specified accuracy.

Sample Rate: 15Hz per channel in all measurement modes.

Digital Resolution: 24 bits.

Measurement Filter: 0.5, 1, 2, 4, 8, 16, 32 and 64 Seconds.

Calibration Curves: Built-in curves for industry standard sensors plus eight user curves with up to 200 entries each. Interpolation is performed using a Cubic Spline.

CalGen™ Calibration curve generator fits any diode or resistor sensor curve at 1, 2 or 3 user specified temperature points.

Input Configurations

A list of the sensor input configurations is shown below:

Type	Excitation	Use
Diode	Constant-Current 10µA DC	Silicon diodes
PTC100, PTC1K	Passive 1.0mA or 100µA AC	Platinum, PTC RTDs
ACR	Constant-Voltage AC	NTC thermistors
TC70	N/A	Thermocouples. External Option Required.

Table 4: Supported Sensor Configurations

Input Performance**Diode Sensors (Type: Diode)**

Configuration: Constant-Current mode, $10\mu\text{A} \pm 0.05\%$ DC excitation.

Note: Current source error has negligible effect on measurement accuracy.

Input voltage range: 0 to 2.24VDC.

Accuracy: $\pm(80\mu\text{V} + 0.005\% * \text{reading})$

Resolution: $2.3\mu\text{V}$

Drift: 25ppm/ $^{\circ}\text{C}$ over an ambient temperature range of $25^{\circ}\text{C} \pm 5^{\circ}\text{C}$.

PTC Resistor Sensors (Type: PTC100, PTC1K)

Configuration: Constant-Current AC resistance bridge mode.

Drift: 15ppm/ $^{\circ}\text{C}$ over an ambient temperature range of $25^{\circ}\text{C} \pm 5^{\circ}\text{C}$.

AC Excitation Frequency: 7.5Hz bipolar square wave.

Range	Max/Min Resistance	Excitation Current	Resolution	Accuracy
PTC100 1mA	500Ω 0.01Ω	1.0mA	$0.1\text{m}\Omega$	$\pm (0.004 + 0.01\%)\Omega$
PTC1K 100 μA	$5.0\text{K}\Omega$ 0.1Ω	100 μA	$1.0\text{m}\Omega$	$\pm (0.05 + 0.01\%)\Omega$

Table 5: Accuracy and Resolution for PTC Resistors

Advanced Use: While rare, some systems are negatively affected by the use of the 7.5Hz square-wave excitation used in the PTC100 range. In this case, the user can switch to 1mA DC excitation by turning AC excitation OFF. In this case, measurements will be affected by DC offsets and drift within the instrument and thermocouple effects in the sensor wiring. Therefore, measurement accuracy is not specified or guaranteed in this mode.

Note: The Model 24C is calibrated with AC sensor excitation. User selection of DC excitation will introduce offset errors in temperature measurement.

Constant-Voltage NTC Resistors (Type ACR)**Configuration:** Constant-Voltage AC resistance bridge**Excitation Voltages:** 10mV, 3.0mV, 1.0mV, 300 μ V, 200 μ V and 100 μ V RMS.**Excitation Current:** 1.25mA to 10nA, continuously variable.**Excitation Ranges:** Full-scale excitation current ranges are 1.25mA, 125 μ A, 12.5 μ A and 1.25 μ A.**Excitation Frequency:** 7.5Hz bipolar square wave.**Accuracy Range:** >4 Ω and < 100K Ω **Drift:** >10 Ω and <10K Ω : 15ppm/ $^{\circ}$ C<10 Ω or >10K Ω : 25ppm/ $^{\circ}$ C**DC Offset Current:** <1/2 excitation current by active cancellation.**Resistance Range:** 0.08 Ω to 1.0M Ω .

Resistance	10mV	3.0mV	1.0mV	300 μ V	200 μ V	100 μ V
Maximum	1.0M Ω	300K Ω	100K Ω	30K Ω	20K Ω	10K Ω
Minimum	8 Ω	2.4 Ω	0.8 Ω	0.24 Ω	0.16 Ω	0.08 Ω

Table 6: Minimum and Maximum Resistance vs. Bias Voltage

Excitation Range	Resolution	Accuracy Vbias = 10mV	Accuracy Vbias = 1mV
1.0mA	0.1m Ω	\pm (0.04% reading + 0.001) Ω	\pm (0.04% reading + 0.01) Ω
100 μ A	1.0m Ω	\pm (0.04% reading + 0.01) Ω	\pm (0.04% reading + 0.1) Ω
10 μ A	10m Ω	\pm (0.04% reading + 0.1) Ω	\pm (0.04% reading + 1) Ω
1.0 μ A	100m Ω	\pm (0.04% reading + 1) Ω	\pm (0.04% reading + 10) Ω

Table 7: Accuracy and Resolution of NTC Resistors

ⓘ Note: Voltage bias (Vbias) settings below 10.0mV are intended for advanced applications that use cryogenic NTC resistor sensors below about 2.0K. Lower settings reduce sensor self-heating but also degrade measurement accuracy and reduce resistance measurement range. Please refer to the section: [Error Sources in NTC Sensor Measurements](#).

Thermocouple Sensors (Type TC70)

Thermocouple devices are supported by using an optional external module. The module is powered by the instrument and performs differential amplification as well as cold-junction compensation.

Measurement Drift: 25ppm/°C **Input Range:** ±70mV
Accuracy: ±1.0µV ± 0.05% **Resolution:** 0.0003%

Installed Types: K, E, T and Chromel-AuFe (0.07%).

Input Connector: Isothermal, Spade-type terminals.

Measurement Resolution and Control Stability

The input analog-to-digital converter used by the Model 24C is 24 bits with no missing codes. Therefore, the measurement resolution is as one part in 2^{24} . Given this high resolution measurement and the use of precision math in the control loop code, the control stability of a control loop is usually limited by the output quantizer DAC rather than the input measurement resolution. All Cryo-con controllers use a digital signal processing technique called *dither* to extend the output resolution to ~20 bits from the more typical 16 bits. Therefore, the output resolution is one part in 2^{20} .

$$CS = FullScale \cdot 2^{-20}$$

$$CST = \frac{CS}{SenSen}$$

Where:

CS is the control stability in sensor units.
 FullScale is the full scale output power of the control loop
 CST is the control stability in temperature units.
 SenSen is the sensor sensitivity at the measurement point.

Input Channel Statistics

Input temperature statistics are continuously maintained on each input channel. This data may be viewed in real time on the Input Channel menu, or accessed via any of the remote I/O ports.

Statistics are:

Minimum Temperature.
 Maximum Temperature.
 Temperature Variance.
 Slope and Offset of the best-fit straight line to temperature history.
 Accumulation Time

The temperature history may be cleared using a reset command provided.

CalGen® Calibration Curve Generator

The CalGen® feature generates new calibration curves for Silicon diode or Platinum sensors. This provides a method for obtaining higher accuracy temperature measurements without expensive sensor calibrations.

Curves can be generated from any user-selected curve and are written to a specified internal user calibration curve area.

The CalGen® function may be performed in the instrument by using the web browser.

Control Loop Outputs

The Model 24C has four control loop outputs. Loop #1 and Loop #2 are powered outputs that directly drive a heater load. Loops #3 and #4 are non-powered outputs that are intended to control an external device.

Specifications common to all four loops include:

Control Input: Any sensor input.

Loop Update Rate: 15Hz per loop.

Digital Resolution: 1.0PPM of full-scale, corresponding to ~20 bits.

Autotune: Minimum bandwidth PID loop design.

PID Tables: Six user PID tables available for storage of Setpoint vs. PID and heater range. Up to 16 entries/table.

Setpoint Accuracy: Six+ significant digits.

Over Temperature Disconnect: Heater may be relay disconnected from user equipment when a specified temperature is exceeded on any selected input.

Control Types

A summary of control types is given here:

Type	Description
Off	Control loop is disabled.
Man	Manual control mode. Here, a constant heater output power is applied. The Pman field selects the output power as a percentage of full-scale.
Table	PID control mode where the PID coefficients are generated from a stored, user supplied PID table.
PID	Standard PID control.
RampP	Temperature ramp control. Uses PID control to perform a temperature ramp.
RampT	Temperature ramp control using a PID table. Uses PID control to perform a temperature ramp.

Table 8: Control Type Summary



Caution: The Model 24C has an automatic control-on-power-up feature. If enabled, the controller will automatically begin controlling temperature whenever AC power is applied.

Loop #1 Primary Heater Output

The Loop #1 heater output is a short circuit protected linear current source. This output is heavily regulated and RFI filtered. External filters should not be necessary.

Load resistance values of either 25Ω or 50Ω may be selected. Using a 25Ω load, the heater will be automatically configured to have a compliance voltage of 25V. With a 50Ω load, the compliance voltage is 50V. In either case, the maximum output current is 1.0A.

Loop #1 has three output ranges of 1.0A, 0.33A and 0.10A full-scale, which correspond to 50W, 5.0W and 0.5W when used with a 50Ω load.

Range	Compliance Voltage		Full-Scale Output Current	Max. Output Power	
	25Ω	50Ω		25Ω	50Ω
High	25V	50V	1.0A	25 Watts	50 Watts
Medium	25V	25V	0.316A	2.5 Watts	5.0 Watts
Low	25V	25V	0.100A	0.25 Watts	0.50 Watts

Table 9: Loop #1 Heater output ranges.

Minimum loads for Loop #1 are 10Ω in 25Ω setting and 40Ω in 50Ω setting.

ⓘ Note: Heater output displays are given as a percentage of output power, not output current. In order to compute actual output power, multiply this percentage by the full-scale power of the selected range. However, to compute actual output current, you must first take the square root of the percentage and then multiply by the full-scale current.

Loop #2 Heater Output

The Loop #2 heater output is a short circuit protected linear current source. This output is heavily regulated and RFI filtered. External filters should not be necessary.

Load resistance for Loop #2 is fixed at 50Ω and the minimum resistance is 10Ω

Loop #2 has Two output ranges as shown in this table:

Range	Compliance	Full-Scale Current	Max. Output Power
High	36V	0.71A	25 Watts
Low	36V	0.22A	2.5 Watts

Table 10: Loop #2 Heater output ranges.

Loop #3 and #4 Outputs

Control loops #3 and #4 are non-powered, short circuit protected voltage outputs that are intended for use with external power supplies.

Output ranges of 0 to 5V or 0 to 10V may be selected. All control modes are supported.

Short-Circuit Output Current: 5.0mA.

Output Impedance: $2,000\Omega$

Heater fault conditions

Loop #1 and #2 heater outputs will be automatically shut down when a fault condition is detected. Here, the heater output will be turned off until the output stage returns to its safe operating area.

If the control loop was disengaged by a detected error condition, the heater status field shows an indicator of the error as follows:

Control Loop Status Indications	
-Htr Off-	Normal display for a control loop that is OFF.
24% HI	Active loop controlling temperature. Percent output power and range are indicated in real time.
-Overtemp-	Indicates that the controller's internal temperature monitor circuit shut off the heater because the internal heat-sink temperature is too high. After the controller has been allowed to cool to an acceptable temperature, pressing the CONTROL button will clear the error and re-start control. Note: The current temperature of the internal heat-sinks for Loop #1 and Loop #2 are displayed in the heater configuration menu.
-Readback-	An independent read-back of the heater output current differs significantly from the current that the controller is attempting to set. This is usually caused by an open heater or a load resistance that is too high.
OTDisconn	Indicates that the control loop was disconnected by the Over Temperature Disconnect Monitor. This monitor is configured by the user and functions to disable the heater if a specified over temperature condition exists on an input channel.
Htr-Low-R	Indicates that the resistance of the heater is too low and can cause overheating of the controller's internal circuits. For Loop #1 set to a 50Ω load, the actual resistance must be >40Ω. With a 25Ω load selected, the resistance must be >10Ω.
Fan Fault	The internal fan speed is too low. This may be caused by blocked air flow or a defective fan.
Control LED ON but no heater output	The controller's watchdog timer has detected an internal fault. If this persists, please contact factory.

Table 11: Control Loop Status Indications

Heater output power output indications are based on an internal heater read-back circuit that measures output current independently of the actual heater. Additional read-backs include load resistance, load voltage and heat-sink temperature.

For a detailed description of control loop status, press the Loop 1 or Loop 2 keys to go to the heater configuration menu. Here, complete status is displayed in real-time.

General

Electrical Isolation and Input Protection

The input channel measurement circuitry is electrically isolated from other internal circuits. However, the common mode voltage between an input sensor connection and the instrument's ground should not exceed $\pm 40V$.

Sensor inputs and outputs are provided with protection circuits. The differential voltage between sensor inputs should not exceed $\pm 15V$.

Relays

The Model 24C has two dry-contact mechanical relay outputs.

Relays are asserted or cleared based on the temperature reading of selected input channels. Each output has a high and low set-point that may be enabled from the front panel or a remote interface. Furthermore, relays can be manually asserted ON or OFF.

Normally-Open contacts are available on the rear panel. Contact rating is 10A @125 VAC, 5A @250 VAC or 5A @30 VDC for resistive loads. Maximum switching power is 150W.

Alarm Outputs

Alarm outputs include a LED indicator, an audible alarm, on-screen display and remote reporting.

Alarms may be asserted based on high temperature, low temperature, input sensor fault or heater fault conditions.

A user selectable dead-band is applied to all alarms.

The High and Low temperature alarms may be latched. See the Input Channel Configuration Menu.

<p>Note: To clear a latched alarm, first press the Alarm key and then press the Home key.</p>
--

Mechanical, Form Factors and Environmental

The Model 24C enclosure is standard 2-U half-width 17-inch rack-mountable type that may be used either stand-alone or incorporated in an instrument rack.

Dimensions are: 8.5"W x 3.5"H x 12"D. Weight is 9 Lbs.

An instrument bail and feet are standard. Rack Mount kits are available from Cryo-con for both single instrument or side-by-side dual configurations. A rack mount kit is optional.

Front Panel Operation

The user interface of the Model 24C Cryogenic Temperature Controller consists of a 40 character by eight line TFT LCD and a keypad. All features and functions of the instrument are accessed via this simple and intuitive menu-driven interface.

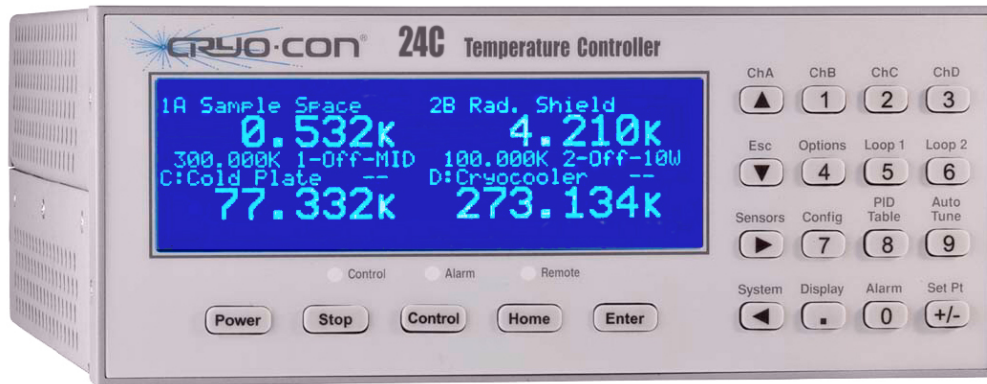

Figure 2: Model 24C Front Panel Layout

The Keypad

Function Keys

The Function Keys on the Model 24C are **Power**, **Stop**, **Control**, **Home**, and **Enter**. These buttons always perform the same function, regardless of the context of the display.

The **Power** key is used to turn AC power to the controller on or off. Note that this key must be pressed and held for one second in order to toggle AC power.

ⓘ Note: The Model 24C uses a smart power on/off scheme. When the power button on the front panel is pressed to turn the unit off, the instrument's configuration is copied to flash memory and restored on the next power up. If the front panel button is not used to toggle power to the instrument, the user should configure the controller and cycle power from the front panel button one time. This will ensure that the proper setup is restored when AC power is applied.

The **Stop** and **Control** keys are used to disengage or engage the instrument's output control loops. Pressing **Control** will immediately turn on all enabled heater outputs and pressing **Stop** will turn them both off. To enable or disable an individual loop, go to the [Loop Configuration Menu](#) menu and select the desired 'Type' of OFF.

The **Home** key is used to take the display to one of the Home Status displays. These displays show the full status of the instrument.

The **Enter** key is used to enter numeric data or selections.

The **Set Pt** key provides immediate access to the setpoints of all control loops.

The Keypad and Setup Menu Keys

The keypad keys can serve a dual function. When the display is showing one of the configuration menus, the keypad is used for navigation and data entry. When the display is in the Home Display, their function is identified by a label printed just above the key and is as follows:

ChA(▲), ChB(1), ChC(2), ChD(3) - Go to the Input Channel Setup menu.

Loop 1(5), Loop 2(6) - Go to the Control Loop Setup menu.

Auto Tune(9) - Go to the auto-tuning menu for either loop.

Config(7) - Go to the User Configurations menu.

Sensors(▶) - Go to the Sensors configuration menu, including sensor calibration curves.

PID Table(8) - Go to the PID tables setup menu.

System(◀) - Go to the System setup menu. This includes fields for Remote Input / Output, Display filters and the Over Temperature Disconnect feature.

Display(.) - Go to the Display setup menu. This allows configuration of the front panel display from a list of options

Alarm(0) - Go to the Alarm Status menu.

Options(4) - Go to the Options Setup Menu.

Keypad Data Entry

The keypad is used to enter data and make selections in the various configuration menus. Fields require the entry of numeric or enumeration data.

Enumeration fields are display fields where the value is one of several specific choices. For instance, the Heater Range field in the Loop 1 setup menu may contain one of only three possible values: HIGH, MID and LOW. There are many enumeration fields that contain only the values ON and OFF.

Enumeration Fields

An enumeration is always indicated by the **+** character in the first column of the field.

To edit an enumeration field, place the cursor at the desired field by using the Navigation keys. Then, use the **+** or **0** keys to scroll through all of the possible choices in sequence.

When a field has been changed, the cursor will flash over the **+** symbol. To select the displayed value, press the **Enter** key. To cancel selection without updating the field, press the **ESC(▼)** key.

To select the displayed value, press the **Enter** key. To cancel selection without updating the field, press the **ESC(▼)** key. The cursor will then return to the **+** symbol.

Numeric Data Fields

Numeric data is indicated by a pound-sign (**#**) in the first column of the field.

The Keypad Keys are used to enter data into numeric fields. These keys are: the numerals **0** through **9**, the period key (**.**) and the **+/-** key.

When the cursor is positioned to a field that requires numeric data, the keypad keys become hot and pressing one of them will result in the field being selected and numeric entry initiated. This is indicated by a flashing cursor.

When the **Enter** key is pressed, numeric data in the selected field will be checked for range and the instrument's configuration is correspondingly updated.

ⓘ Note: If the numeric entry is outside of the required range, an error is indicated by the display of the previous value of the field.

Once the entry of numeric data has started, it can be aborted by pressing the **Home** key. This will cause the field to be de-selected and its value will be unchanged. Pressing the **ESC(▼)**, key will exit data entry and restore the field to its previous value. The **◀** key can be used as a backspace.

ⓘ Note: Up to 20 digits may be entered in a numeric field. When digit entry has exceeded the display field width, additional characters will cause the display to scroll from right to left.

Summary of keypad functions

Key	Function	Description
	Power	Toggle power. Must be held in for two seconds.
	Stop	Disengage all control loops.
	Control	Engage all control loops.
	Enter	Enter key
	Home	Go to the Home Status Display.
▲	ChA	Input Channel Menu for Channel A. / Scroll Display UP
▼	ESC	If in data entry mode, Escape. Additionally, if the keypad has been locked by a remote interface, pressing this key will unlock it and clear the Remote LED / Scroll Display DOWN.
▶	Sensors	Go to the sensor setup menu / Scroll Display RIGHT
◀	System	If in data entry mode, backspace. From home display, go to the System setup menu / Scroll Display RIGHT.
.	Display	Go to the display configuration menu.
±	Setpoint	Change the setpoint value for either control loop. / Scroll to NEXT selection.
0	Alarm	Go to the Alarm Status menu. / Scroll to PREVIOUS selection
1	ChB	Input Channel Menu for Channel B.
2	ChC	Input Channel Menu for Channel C.
3	ChD	Input Channel Menu for Channel D.
4	Options	Options Setup Menu. Loop 3 and 4 setup menus.
5	Loop 1	Go to the Loop 1 setup menu.
6	Loop 2	Go to the Loop 2 setup menu.
7	Sensors	Sensor data and calibration curve menu.
8	PID Table	PID table menu.
9	Auto Tune	Autotune menu.

Table 12: Keypad key functions.

The LED indicators and Audible Alarm

There are three LED indicators located just below the main display.

The blue **Control** LED is illuminated whenever either of the control loops are engaged and actively controlling temperature. To disengage the loops, press the **Stop** key.

The red **Alarm** LED is illuminated whenever a user programmed alarm has been triggered. To clear the alarm, the enabled event that is asserting the alarm must be disabled. Press the **Alarm** key to view the status of all alarms.

In the case of a latched alarm, the alarm condition is cleared by pressing the Alarm(0).

The green **Remote** LED can be turned on or off under program control by the remote interface. Use of this LED by a computer connected to the instrument is optional. To clear the LED and the keypad lockout, press the **ESC(▼)** key.

The Front Panel Display

Home Status Displays

At the top of the instrument's menu tree are the home status displays. They can be selected from anywhere in the instrument's menu tree by pressing the **Home** key. There are four zones, each of which may be independently configured.

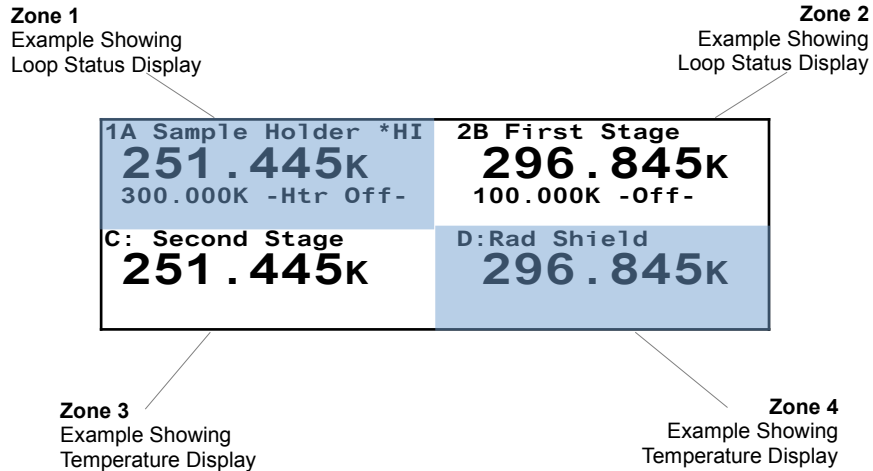

Loop Status Display

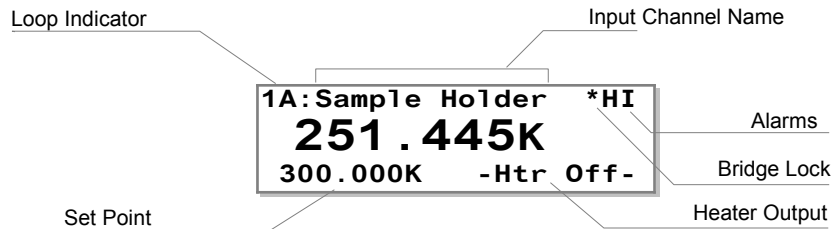

The loop indicator of 1A in the upper left corner indicates Loop #1 with a source input channel of A.

If the control loop was disengaged by a detected error condition, the heater status field shows an indicator of the error. If the control loop is actively engaged, a bar chart showing the heater range and output level is displayed. Vertically, the bar is 7 pixels tall for the HI range, 5 pixels for the MID range and 3 pixels for the LOW range.

Temperature Display

A typical Input Channel Temperature Display consists of the input channel indicator, a Temperature reading and the current temperature units. Optionally, a description of the temperature sensor may be shown.

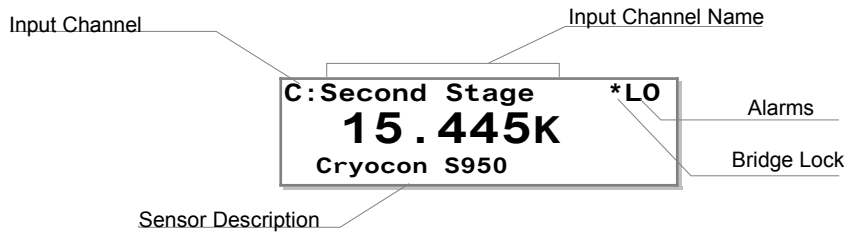

The temperature, a seven-character field, is affected by the Display Resolution setting in the **System** menu. It may be 1, 2, 3 or Full. Settings of 1, 2, or 3 indicate the number of digits to the right of the decimal point to display whereas the Full setting causes the display to be left justified in order to show the maximum number of significant digits possible.

If the Input Channel has been disabled, a blank display is shown.

Temperature Units may be K, C or F. When Sensor Units (S) is selected, the raw input readings are shown. These will be in Volts, Ohms or, in the case of a thermocouple, millivolts.

K	Kelvin
C	Celsius
F	Fahrenheit
Ω	Ohms
V	Volts
m	millivolts

Table 13: Temperature Units

Bridge Lock Indicator

The asterisk (*) character shown in the above Temperature Display is the Bridge Lock Indicator. An asterisk indicates that the resistance bridge is not locked. This may indicate that it is still auto-ranging or that the sensor resistance is too high or too low for the selected voltage bias. However, temperature readings will still be correct.

Sensor Fault Display

A sensor fault condition is identified by a temperature display of seven dash (-) characters as shown here. The sensor is open, disconnected or shorted.



Temperature Out of Range Display

If a temperature reading is within the measurement range of the instrument but is not within the specified Sensor Calibration Curve, a display of seven dot (.) characters is shown.

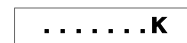

ⓘ Note: In some cases, there will be an erratic temperature display when no sensor is connected. This is not an error condition. The high input impedance of the controller's input preamplifier causes erratic voltage values when left unconnected. If an input is left unconnected, the sensor type should be set to type "None", which turns the input off.

Raw Input Measurement Display

There are times when it is useful to display both the temperature on an input along with the raw measurement. This is accommodated by selecting the Raw Input display from the display configuration menu.

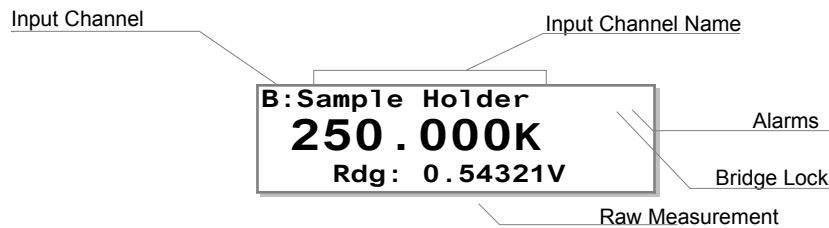

Control Loop Setpoint Display

The control loop setpoint display shows the setpoint for a selected control loop. Frequently, this display is set directly below the loop status display so both the current temperature and the setpoint are shown in large fonts.

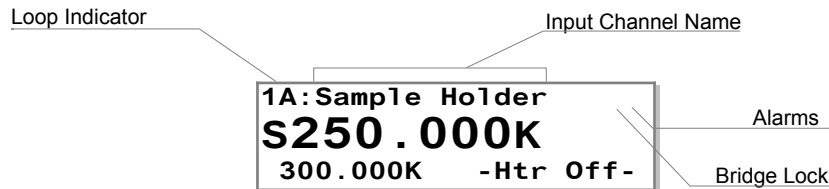

Input Channel Statistics Display

The Channel A, B, C and D statistics displays show the selected input channel temperature, the slope of the temperature history, the minimum and maximum temperatures.

When any of the statistics pages are displayed, pressing the **Enter** key will reset the accumulation.

Instrument Setup Menus

To access the various instrument setup menus, press one of the Setup Menu keys. The display must be in 'Home Status' in order for these keys to be active.

The user may exit a Setup Menu and return to the Home Status display at any time by pressing the **Home** key.

Menus contain several lines, so scroll through the display using the Navigation keys. The last character of each line in a setup menu is the format indicator. The indicator will be blank until the cursor is moved to the line.

Format indicators are:

- # - Numeric entry.
- + - Enumeration entry using the **+** and **0** keys.
- - The line is selected by pressing the **Select** key.

The Setpoint Menu

The setpoint menu is accessed by pressing the **Set Pt** key. This gives one-key access to the setpoints for all of the control loops.

Press the **Home** key to exit the menu without update.

The Alarm Status Display Menu

The current status of the temperature alarms may be viewed by pressing the **Alarm** key.

Alarms are set for each input channel using the Input Channel Setup menu described below.

When an alarm is asserted, the Alarm LED on the front panel will light. Pressing the **Alarm** key will display all of the alarms. Status is shown as follows:

—	No alarm
LO	Low temperature alarm
HI	High temperature alarm

The letter **L** at the end of the line indicates that the alarm is latched. A latched alarm is asserted when the alarm condition is set. It stays asserted until it is manually cleared by the user.

① **Note:** To clear a latched alarm, first press the **Alarm** key to view the alarms and then press the **Home** key to clear the latch and return to the Home display.

Input Channel Configuration Menu

These menus contain all of the user-configurable parameters for a selected sensor input channel.

Use the navigation keys to move around the list.

When the cursor (+) is located to the left of the ChA indicator, channels B, C and D may be displayed by pressing the + key. To sequence in the reverse direction, press the 0 key.

ChA: Sample Holder	
+ 1.543K --	High Alarm: 100.00 High Alarm Enable: No Low Alarm: 10.00 Low Alarm Enable: No Deadband: 0.25 Latched Enable: No Audible Enable: No
Sen: 32 RO-600	
Input Config	
CalGen	
Statistics	

Input Channel Configuration Menu		
1	+ 1.543K --	Input channel units. Selections are K, C, F or S. Here, S selects primitive sensor units. When S is selected, the actual sensor units of Volts or Ohms will be displayed.
2	+Sen: 20 Pt100 385	Sensor type selection. Allows selection of any user or factory installed sensor. The 20 shown indicates that the current sensor is number 20.
3	•Input Config.	Go to the input configuration menu.
4	•CalGen	Go to the CalGen® screen.
5	•Statistics	Go to the input channel statistics screen.
6	#High Alarm: 200.000	Setpoint for the High Temperature alarm. Use the keypad for numeric entry and then press the Enter key.
7	+High Enable: No	High temperature alarm enable. Selections are Yes or No.
8	#Low Alarm: 200.000	Setpoint for the Low Temperature alarm.
9	+Low Enable: Yes	Enables latching alarms on the selected input channel.
10	#Deadband: 0.250	Alarm dead-band.
11	+Audible Ena: Yes	Enables the internal audio alarm to sound on any enabled alarm condition.
12	+Latch Enable: Yes	Enables or disables latching alarm conditions. A latched alarm is cleared by pressing the Alarm key followed by Home key.

Table 14: Input Channel Configuration Menu

Setting a Temperature Alarm

The Alarm lines are used to setup alarm conditions. The Model 24C allows alarm conditions to be assigned independently to any of the input channels.

High temperature and low temperature alarms may be entered and enabled. Note that a user selected dead-band is applied to the assertion of high and low temperature alarms.

Alarm conditions are indicated on the front panel by the Alarm LED and various display fields. They are also reported via the remote interfaces.

When the audible alarm is enabled, a high-pitched buzzer will sound when an alarm condition is asserted.

The Model 24C supports latched alarms. These are alarms that remain asserted even after the condition that caused the alarm has been cleared. To clear a latched alarm, first press **Alarm** to view the Alarm Status Display and then press the **Home** key to clear.

Input Channel Statistics

The Model 24C continuously tracks temperature history on each input channel. The Input Statistics shown in this menu provides a summary of that history.

The channel history is reset whenever the channel is initialized and can also be reset by pressing the **Enter** key while the cursor is on any of the statistics lines.

The **Accum** line shows the length of time that the channel history has been accumulating. It is in units of Minutes.

The **Minimum** and **Maximum** temperature lines show the temperatures from during the accumulation time. Values are shown in the currently selected display units.

S2 is the temperature variance, which is computed as standard deviation squared.

The **M** and **b** fields display the slope and the offset of the LMS best-fit straight line to the temperature history data.

Loop Configuration Menu

These menus contain all of the user-configurable parameters for the selected control loop.

The Loop #1 menu is used to perform the setup of the primary 25/50-Watt heater output. This display was designed to provide all of the information required to tune heater parameters.

Loop 1A: Sample Holder	
Set Pt: 300.000K	A: 1.234K
Pgain: 5.0000	1-Off-Low -Htr-Off
Igain: 60.000S	Range: LOW
Dgain: 7.5000/S	PID Table index: 1
Pman: 5.0000%	Htr Load: 50Ω
Type: Man	Next
Input: ChA	

Loop #1 and #2 menus can be accessed directly from the front panel. Loop #3 and #4 can be accessed by first pressing the **Options** key.

When the cursor is on the top line, the user can scroll through all of the control loop menus by pressing the **+** or **0** keys.

Loop Configuration Menu		
1	#Set Pt: 300.000K	Numeric setpoint entry.
2	A: 299.99K	Indicator of the controlling input channel and it's current temperature.
3	1-Off-LOW -Htr-Off-	Status indicator for the control loop.
4	#Pgain: 25.0000	Proportional gain, or P term for PID control.
5	#Igain: 71.0000S	Integrator gain term, in Seconds, for PID control.
6	#Dgain: 71.0000/S	Derivative gain term, in inverse-Seconds, for PID control.
7	#Pman: 25.00%	Output power, as a percent of full scale, when controlling in the Manual mode.
8	+Input: ChA	Control input channel, ChA, ChB, ChC or ChD.
9	+Range: HI	Output power range.
10	+Type: PID	Control Type
11	#Power Limit: 100%	Power limit as a percent of full scale. On loop 1, this limit only applies to the HI range.
12	#Max Setpt: 1000.00K	Maximum value allowed for the setpoint on this loop.
13	#PID Table index: 0	Table number for control in Table mode.
14	+Htr Resistance: 50Ω	Sets the heater load resistance.
15	#Ramp: 0.10 /min	Ramp rate in temperature units per minute.
16	Next	Go to the next page of the control loop setup menu.

Table 15: Control Loop Setup Menus.

Setpoint

Numeric Entry

In the first line of this menu the user can change the setpoint, while still viewing the temperature of the controlling source channel. This allows the user to view the temperature without leaving the setup menu.

Note: Entry of a setpoint can be overridden by the Maximum Setpoint field described below. The instrument will not accept an entry that exceeds the maximum.

Control loop setpoints may also be entered by using the **Set Pt** key.

Control Loop PID values

Numeric Entry

The Pgain, Igain and Dgain lines correspond to the Proportional, Integral and Derivative coefficients of the control loop. Pman is the output power that will be applied to the load if the manual control mode is selected.

Values for the Proportional, or P, gain term range from zero to 1000. This is a unit-less gain term that is applied to the control loop. Gain is scaled to reflect the actual heater range and the load resistance.

Integrator gain values range from zero to 10,000. The units of this term are Seconds. A value of zero turns the integration function off.

Derivative gain values have units of inverse Seconds and may have values from zero to 1000. A value of zero turns the Derivative control function off.

The Pman field is only used when the heater output is in manual control mode. The value is represented in percent of full-scale output power (Watts) and may have values from zero to 100%.

Note: The Model 24C expresses heater output values in terms of percent of full-scale output power. The actual power, in Watts, applied to the load is proportional to the square-root of output current.

Control Source Input Channel

Enumeration

The input filed selects the control loop source input. Any input channel may be selected.

Control Loop Range

Enumeration, Default: Low

The Range field selects the full-scale output for the selected control loop.

Control Types

Enumeration, Default: Man

The Type filed selects the actual control algorithm used for the selected loop.

Output Power Limit

Numeric entry, Default: 100%

The Power Limit field defines the maximum output power that the controller is allowed to output. It is a percent of the maximum possible output. Maximum value is 100% and minimum is 1%.

Note: Output Power Limit is an important cryostat protection feature. The user is encouraged to apply it.

Maximum Setpoint

Numeric Entry, Default: 1000K

The Maximum Setpoint field is used to prevent the casual user from inadvertently entering a temperature that might damage the cryostat.

Maximum value is 10,000K and minimum is 0 K.

Setpoint values use the temperature units selected for the controlling input channel. See the section on [Temperature Displays](#).

Note: The Maximum Setpoint selection is an important cryostat protection feature. The user is encouraged to apply it.

PID Table Index

Numeric entry, Default: 0

The PID Table index line is used to identify the number of the user supplied PID Table that will be used when the Table control mode is selected. The Model 24C will store up to six PID Tables. They are numbered zero through five.

Heater ResistanceEnumeration, Default: 25 Ω

The heater resistance field is an enumeration that sets the value of the heater load resistance. Choices are 50 Ω and 25 Ω . When 50 Ω is selected, the heater will output a maximum of 50 Volts at 1.0 Ampere or 50 Watts. When 25 Ohms is selected, the maximum heater voltage is 25 Volts and the output power is 25 Watts.

For additional information, please refer to the [Loop 1 Heater output ranges](#) or the [Loop 2 Output Ranges](#) tables.



Warning: It is necessary to set the Load resistance field to the actual value of the heater load resistance being used. If an incorrect value is selected, output power indications will be incorrect non-linear heater operation may result. If the actual heater resistance is less than selected, the heater may overheat resulting in an automatic over temperature shutdown.

Ramping Rate

Numeric entry, Default: 0.10/min

When performing a temperature ramp, the Ramp field defines the ramp rate. Units are display units per minute. In the default case, this means Kelvin per minute.

For more information on temperature ramps, refer to the section on [Temperature Ramping](#).

User Configurations Menu

The User Configurations Menu is displayed by pressing the **Config** key. It is used to save or restore up to four instrument setups. Each setup saves the entire state of the Model 24C including setpoints, heater configurations, input channel data etc.

User Configurations Menu		
1	•Save	Pressing the Enter key saves the instrument setup to the selected configuration number.
2	•Recall	Pressing the Enter key restores a saved configuration.

Table 16: User Configurations Menu

Saving a User Configuration

In the **Config** menu, navigate to the Save field of the desired configuration. Press the **Enter** key to execute the save.

Restoring a User Configuration

First, press the **Config** key and navigate to the Recall field of the desired configuration. Press the **Enter** key to execute the restore.

The System Configuration Menu

This menu is accessed by pressing the **System** key from the Home Status Display. It is used to set many of the instrument's parameters including display resolution, I/O port settings etc.

System Configuration Menu			
Display TC:	4S	FW Rev:	3.19G
Display Res:	3	Serial Number:	209999
Network Config		Pwr Up In Ct1:	No
RS232:	9600	AC Line:	60Hz
GPIB Adrs:	12	Date:	08/01/2009
Datalog Config		Time:	12:12:42
Over Temp Config			

System Configuration Menu		
1	+Display TC: 4S	Sets the display time constant, in seconds, for all temperature displays. Range is 0.5S to 64S
2	+Display Res: 3	Sets the resolution. Selections are: 1, 2, 3 or Full.
3	●Network Config	Press Enter to go to the network configuration menu.
4	+RS232: 9600	Sets RS-232 port baud rate
5	+GPIB Adrs --	Sets GPIB address. It is a numeric entry with a range of 1 to 31. Note: GPIB is an external option, – indicates that option is not connected.
6	●Datalog Config	Press Enter to go to the data logging setup screen.
7	●Over Temp Config	Press Enter to go to the Over Temperature Disconnect configuration screen.
8	FW Rev:3.19F	Displays the firmware revision level and hardware revision letter.
9	+Pwr Up In Ct1: OFF	Power Up Mode. Off for normal operation. On to engage the control loops 10 seconds after power has been applied.
10	+AC Line: 60Hz	AC line frequency. Select 50 or 60Hz.

Table 17: System Configuration Menu

Display Time Constant

Enumeration, Default: 4 Seconds

The **Display TC** field is used to set the display time-constant. This is an enumeration field that sets the time constant used for all temperature displays. Choices are 0.5, 1.0, 2.0, 4.0, 8.0, 16.0, 32.0 and 64 Seconds.

The time-constant selected is applied to all channels and is used to smooth data in noisy environments. The filtering only applies to displayed data; it is not used by the control loops.

Display Resolution

Enumeration, Default: 3

The Display Resolution line (**Display Res**) is used to set the temperature resolution of the front panel display. Settings of 1, 2 or 3 will fix the number of digits to the right of the decimal point to the specified value. A setting of FULL will left-justify the display to show maximum resolution possible.

Note that the Display Resolution setting only formats the display as a user convenience. The internal resolution of the Model 24C is not affected by this setting.

AC Line Frequency Selection

Enumeration, Default: 60Hz

Select the AC power line frequency. Choices are 50 or 60 Hz.

Power-up in Control Mode.

Default: Off

The Auto Ctl: field sets the power up mode of the controller's loops. Choose 'Off' for normal operation where the control loops are engaged by pressing the **Control** key and disengaged by pressing the **Stop** key. When on, the controller will power up, then after ten seconds, will automatically engage the control loops.



Caution: When enabled, the Power-Up in Control mode feature causes the controller to engage the control loops automatically whenever AC power is applied. Please exercise caution in the use of this feature.

Over Temperature Disconnect Configuration

Navigate to the OTD Configuration menu by pressing the **System** key and then selecting the Over Temp Config field.

The Over Temperature Disconnect (OTD) feature monitors a selected input channel for an over temperature condition. If this exists, all heaters outputs are disconnected and the Loop Status indicator is set to "OTDisconn". A mechanical relay is used for the disconnect so that the load is protected, even if the condition was caused by a fault in the controller's output circuitry.

The OTD must first be configured to monitor one of the input channels. Note that the OTD feature is completely independent of control loop function and may monitor any input.

Next, an OTD Setpoint must be specified. This is the temperature at which an over temperature shut down is asserted. Temperature units are taken from the source input channel.

Finally, the OTD function must be enabled.



Important: The Over Temperature Disconnect is a cryostat protection feature. The user is encouraged to apply it.

Over Temperature Disconnect Configuration		
1	+OTD Enable: Off	Sets the Over Temperature Disconnect enable. Selections are On or Off.
2	+OTD Source: ChA	Sets the Over Temperature Disconnect source input channel. Selections are ChA or ChB.
3	#OTD T: 300.000	Sets the Over Temperature Disconnect setpoint temperature.

Table 18: Over Temperature Disconnect Configuration

Data Logging Configuration Menu

The data logging function records all four input temperatures, control loop outputs and relay states along with a real-time clock stamp.

The log buffer is circular and contains 1365 entries. Then the maximum number of entries is exceeded, the oldest samples are written over. The buffer is

maintained in Non-Volatile memory and will therefore survive a power failure.

```

DataLogging Configuration Menu
+State: ON
#Interval: 5   Sec
Count: 562
Last Log: 8/1/2010 13:15:09
Press Enter to delete data log buffer

```

DataLogging Configuration Menu	
+State: ON	Turns logging ON and OFF.
#Interval: 5 Sec	Sets the Data Logging interval in units of Seconds. Minimum is 1 and maximum is 99,999.
Count: 1365	Number of records in the log buffer.
Last Log: 8/1/2010 12:59:50	Date / time stamp of last record recorded.
Press Enter to delete data log buffer	

Logged data can be read via any of the remote interfaces as follows:

PuTTY terminal emulator: Enter the command DLOG?. Note: you should setup a receive file to store the data before executing this command because a large volume of data is returned.

Cryocon Utility Software: Click on the Upload Internal Datalog button. This will enable reading the log buffer to a spreadsheet .csv file.

Network Configuration Menu

Navigate to this menu by pressing the **System** key and selecting the Network Config field.

Network Configuration Menu		
1	Dev : M24C1234	Instrument name reported over the LAN. May be modified by using the embedded web page.
2	#IP : 192.168.1.5	Network IP address. Numeric entry. Factory default is 192.168.1.5.
3	#MSK : 255.255.255.0	Network subnet mask. Numeric entry. Default is 255.255.255.0
4	#Gwy : 192.168.0.1	Network gateway. Only used if the instrument is to be connected through a gateway to the Internet. Default is 192.168.0.1.
5	#Port : 5000	TCP/IP port assignment. Default is 5000. The UDP port assignment is always the TCP/IP port plus 1 (Default: 5001).
6	00:50:C2:6F:40:3F	Media Access Control (MAC) address. Unique for each instrument.
6	+DHCP Ena : OFF	Enable DHCP IP address assignment.
8	>	Remote I/O: Last command received.
9	<	Remote I/O: Last response.

Table 19: Network Configuration Menu

Local Area Network Setup

Setup of the Local Area Network requires a device name, an IP address, a subnet mask and a gateway.

The device name is any 15 character string. It is reported on the display, but can only be changed via a remote command. The name is used by LAN systems that have name servers. In this case, the instrument can be addressed by it's name rather than it's IP address.

The IP address uniquely identifies the instrument on the LAN. The factory default is 192.168.1.5.

The subnet mask is used to divide the LAN addresses into segments. The default subnet mask is 255.255.255.0.

A gateway IP address need only be entered if the instrument communicates with the Internet via a gateway. The factory default gateway is 192.168.1.1, which is used in systems with Internet Connection Sharing.

PID Tables Menu

The Model 24C can store six user generated PID tables. Each table may have up to sixteen setpoint zones.

Each setpoint zone in a table requires the entry of a setpoint along with corresponding values for P, I, D and full-scale heater range.

When controlling in the Table mode, the Model 24C will derive control loop PID coefficients and heater range by interpolation of the PID Table zones based on that zone's setpoint.

PID Tables can be used with both control loops.

Building a table from the front panel requires the entry of several numeric values. For this reason, the user may want to consider using one of the remote interfaces.

The start, and top level, of this process is the PID Tables menu. Two menu screens below this are used to enter numeric data. Here is an overview of the process:

1. The PID Tables menu is used to select the PID Table number (zero through three).
2. Once the table is identified, selecting the EDIT PID TABLE line will take the menu used to edit individual lines of the selected table.
3. To enter or edit an entry, set the desired entry index and enter the zone data on the following lines.
4. The last line of this menu is used to save the table when the entire table is complete.

When a table is saved, it is automatically conditioned so that it can be used directly by the control loop software. The conditioning deletes all entries with setpoint values of zero or less and sorts the table based on setpoint. Therefore, an entry may be deleted by setting the setpoint to any negative number.

The PID Table Menu

The PID Table Menu is accessed by pressing the **PID Table** key from the Home Display and then selecting a table.

The first line of this display shows which PID table is being edited. Placing the cursor on this line will allow the user to scroll through all of the tables.

Edit PID Table 01		
Table Index:	00	
P:	1.60	Setpt: 300.00K
I:	160.0S	Ch: Default
D:	40.0/S	Range: HI
SaveTable&Exit		

PID Table Edit Menu	
+Table Index	Sets the line number to edit.
#P	P gain value
#I :	I value in units of Seconds.
#D :	D value in units of inverse-Seconds.
#SetPt	Setpoint in units of temperature.
+Ch :	Input channel. Can be set to any input or to default where default is the input channel shown in the loop setup menu.
+Range :	Heater range setting.

Table 20: PID Table Edit Menu

Pressing the **ESC(▼)** key from this menu will abort the line entry process and return the display to the PID Table Menu above. Any edits made to the line will be lost.

When a table index is selected, all of the lines on this menu will be updated to show the selected line. Any data in the selected index will be displayed on the following lines.

The following data can be entered into the PID zone: Setpoint (SP), Proportional gain (P), Integral gain (I), Derivative gain (D) and heater range.

To delete a zone from the PID Table, enter zero or a negative number in the setpoint field. These entries will be rejected when the table is conditioned and stored in Flash memory.

Save the entire table by scrolling to the last line, **SaveTable&Exit**, then press the **Enter** key.

Sensor Setup Menu

The Sensor Setup menu is used to view and edit user temperature sensor data.

The Sensor Header Edit Menu

Pressing the **Sensor** key from the Home Status Display accesses the Sensor Setup Menu. From there, the Sensor Header Edit Menu can be accessed by scrolling to the sensor and pressing **Enter**.

Definition of a sensor requires entering configuration data on this screen followed by entering a calibration curve.

Sensor Header Edit Menu	
+Type: Diode	Sets the Sensor Type.
#Mult: -1.0	Sets the sensor Temperature Coefficient and Calibration Curve Multiplier.
+Units: Volts	Sets Units of the sensor's Calibration Curve. Choices are: Ohms, Volts and LogOhm.

Table 21: Sensor Setup Menu

The first line on this menu is the sensor table index. Selecting this field allows the user to scroll through all of the sensors configured in the unit, including user sensors. The index is displayed along with the sensor name.

Note: the sensor name may be entered via any of the Remote I/O interfaces, but may not be changed from the front panel.

Sensor Type is an enumeration of all of the basic sensor types supported by the Model 24C. Choices are shown in the [Supported Sensor Configurations](#) table above.

The **Multiplier** field is a floating-point numeric entry and is used to specify the sensor's temperature coefficient and to scale the calibration curve. Negative multipliers imply that the sensor has a negative temperature coefficient. The absolute value of the multiplier scales the calibration curve. For example, the curve for a Platinum sensor that has 100Ω of resistance at 0°C may be used with a 1000Ω sensor by specifying a multiplier of 10.0. Also note that the temperature coefficient field is only used when the unit is controlling temperature based on the sensor units of Volts or Ohms.

Units is an enumeration field that identifies the primitive units used by the sensor's calibration curve. Choices are Volts, Ohms and LogOhm. LogOhm selects the base ten logarithm of ohms and is useful with sensors whose resistance vs. temperature curve is logarithmic.

The Calibration Curve Edit menu

From this screen, the user can input individual entries into a sensor calibration curve. Note that these curves can have up to 200 points requiring the entry of 400 floating point numeric values. For lengthy curves, you may want to consider using one of the remote interfaces. Cryocon provides a free PC utility that uploads or downloads curves which can be created by a text editor.

The Calibration Curve Edit menu is accessed by pressing the **Sensor** key, scrolling to the desired curve and then scrolling to the Edit field of that curve.

The procedure for entering or editing a calibration curve is summarized as follows:

1. First, set the index (IX) field to the curve entry that you want to enter. This will cause the display of data at that index.
2. Enter data points values by entering numeric data and pressing **Enter**.
3. Go to the next index by changing the IX field.
4. When all data points have been entered, the SaveCurve&Exit field is selected to save the curve.

Once complete, the controller will condition the curve by rejecting invalid entries, then sorting the curve in order of ascending sensor unit values. Therefore, an entry may be deleted by placing a zero or negative number in the temperature field.

Calibration Curve Menu	
#IX: 123	Sets the current index to an entry within the current table. Values are 0 to 159. When the Enter key is pressed, the following lines will display any data corresponding to the selected entry.
#T: 232.0050	Temperature. Units are always in Kelvin.
#S: 1.00002	Sensor reading. Units are taken from the Sensor Setup menu described above and may be Volts, Ohms or Logohms.
•SaveCurve&Exit	Pressing Enter save entered data and exit the menu. To exit without saving, press the Home key.

Table 22: Calibration Curve Menu

Basic Setup and Operation

Selecting a Sensor

Configuring an input sensor from the front panel is performed by using the Input Channel Configuration Menu. First, press input channel key **ChA**, **ChB**, **ChC**, or **ChD** to select the desired channel for configuration.

The second line of the Input Channel Configuration menu is used to change the sensor units. It shows the selected input channel, the current temperature (in real time) and the current units. An example is shown here.

ChA: Sample Holder	
+ 1.543K --	High Alarm: 100.00
	High Alarm Enable: No
	Low Alarm: 10.00
Sen: 1 Cryocon S950	Low Alarm Enable: No
Input Config	Deadband: 0.25
CalGen	Latched Enable: No
Statistics	Audible Enable: No

To change the sensor units, use the **+** and **0** keys to scroll through the available options. When the desired units are shown, press the **Enter** key to make the selection. The display will now show the current temperature with the new units.

Next, go to the sensor selection field by pressing the down arrow navigation key. This field is used to select the actual sensor type. In the example shown here, the input channel is currently configured for a standard Cryo-con S950 diode sensor. Use the **+** and **0** keys to scroll through the available sensors including user sensors. When the desired sensor is shown, press the **Enter** key to make the selection.

Select **None** to disable the input channel.

At the end of the factory-installed sensors, eight user-installed selections will be shown. The default name for these are User Sensor N, but, this name can be changed to give a better indication of the sensor type that is connected. Before one of these user-supplied sensors can be used, the sensor's calibration curve and configuration data must be installed. This is best done by using Cryo-con's utility software.

A complete listing of selectable sensors is given in [Appendix A](#).

Note: NTC resistor sensors require the selection of a Bias Voltage and optionally, an excitation range.

This completes the process of configuring an input channel. Press the **Home** key to return to the Home Status display.

Using NTC Sensors (Type: ACR)

The Model 24C supports all types of Negative-Temperature-Coefficient (NTC) resistor sensors that are often used as low temperature thermometers, especially at ultra-low range. Examples include Ruthenium-oxide (RuOx), Carbon-Glass, Cernox™, Carbon-Ceramic, Germanium and several others.

Error Sources in NTC Sensor Measurements

At warm temperatures, NTC sensors have very low sensitivity so the major source of error is the measurement electronics itself. Accuracy can only be improved by increasing the sensor excitation power.

Conversely, at low temperature, NTC resistors have high resistance and the primary source of error is sensor self-heating. They have high sensitivity in this region, so measurement errors are small when viewed in units of temperature.

Constant-voltage sensor excitation increases signal power at warm temperature, thereby improving measurement accuracy in an area where the sensor is less sensitive. At low temperature, constant voltage excitation reduces the power dissipated in the sensor which reduces accuracy in units of Ohms, but more importantly, reduces sensor self-heating. Since low temperature is the sensor's most sensitive area, measurement accuracy in units of temperature will not be degraded. The result is an accuracy improvement that extends the useful temperature range of a given sensor at both the warm and cold ends.

Another common source of error at ultra-low temperature is sensor self-heating due to DC offsets in the measurement electronics. The Model 24C resistance bridge measures the actual current flowing through the sensor to actively cancel DC offsets by using a feedback loop to offset its excitation source.

Ultra-low temperature systems can be negatively affected by coarse steps in excitation current. The Model 24C prevents this by using a step-less, continuously variable excitation source. Since the Model 24C computes resistance by measuring both the excitation current and the voltage-drop across the sensor, measurement accuracy is not reduced by the use of continuously variable excitation.

Power dissipation in the sensor is determined by the voltage applied to the sensor and the resistance of the sensor itself.

The actual power being dissipated in the sensor may be viewed in real-time by going to the Input Configuration Menu.

Installing a Custom NTC Sensor Calibration Curve

NTC sensors often require custom calibrations. Therefore, the first step in using these sensors is often to install a sensor calibration curve. Please refer to the chapter “[Downloading a Sensor Calibration Curve](#)”.

NTC resistor sensor curves always use the Sensor Type of ACR. The desired voltage bias may optionally be entered next to ACR on the second line of the curve file.

Calibration curves for NTC sensors may be entered either directly in Ohms or in (base 10) Log-of-Ohms. Since curves for these sensors are often logarithmic nature the use of **LogOhms** in the calibration curve will usually give better interpolation results than **Ohms**.

NTC Sensor Configuration

To complete the configuration of an NTC sensor, go to the Input Channel Setup menu then select the Input Config field. The NTC Sensor Configuration will now be displayed. An example of this menu is shown here.

Temperature and sensor power dissipation are shown in real-time.

Temperature units can be changed by navigating to the temperature display field.

ChA: Sample Holder		
NTC Sensor Configuration		
+	0.241K*	Pd: 1.66e-10W
	Bias Voltage: 10mV	
	Bridge Range: Auto	
Return to ChA cfg		

ⓘ Note: The astrisk (*) character shown next to the temperature in the above display is the Bridge Lock Indicator. A blank character indicates that the bridge is locked. But, an astrisk character indicates that the bridge is auto-ranging or that it cannot establish the selected bias voltage. Usually, the resistance reading is accurate and stable.

Selecting Sensor Voltage Bias

Voltage bias is the excitation voltage-drop that will be maintained across the sensor. Available levels are 10mV, 3.0mV, 1.0mV 300 μ V, 200 μ V and 100 μ V with the default being 10mV. Higher voltages improve accuracy at warm temperature and lower levels reduce self-heating at cold temperature. The user must select a level that maximizes accuracy over the desired temperature range. Generally, sensors operating above about 2K use the 10mV setting. Below that, selection is more difficult because it depends on the sensor's resistance and cryostat's thermal design. To select a voltage bias in the low temperature region:

1. Establish the sensor at the lowest possible temperature and use the lowest value of bias voltage that will read the sensor's resistance.
2. Increase the voltage bias until a rise in temperature is noted and then reset the bias to the just previous value.

Selecting a Bridge Range

Bridge Range controls the excitation current ranges that the bridge is allowed to use. It is generally set to Auto so that the optimum excitation is automatically selected.

Some systems are sensitive to the brief transients that auto-ranging can generate. In this case, the bridge range can be fixed at 1.0mA, 100uA 10µA or 1.0µA.

Remote Commands commonly used with ACR sensors

The following remote commands that are commonly used with ACR type sensors:

INPut:SENPr? reports the primitive reading on a selected input channel. For diode sensors, the reading is in Volts while resistor sensors are reported in Ohms. The reading is not filtered by the display time-constant filter. Useful whenever measurements of both temperature and sensor resistance are required.

INPut:VBias Sets or queries the sensor voltage excitation setting.

INPut:BRANge Sets or queries the resistance bridge range. Default is Auto.

INPut:CBR? Queries the current bridge range setting. Useful to find the actual range setting when Bridge Range is set to Auto.

INPut :POWER? Queries the instantaneous power being dissipated in the sensor.

INPut :BRUNlock? Queries the Bridge Lock Indicator indicator.

Using PTC resistor sensors

The Model 24C supports all types of Positive-Temperature-Coefficient resistor (PTC) sensors. Examples include Platinum, CLTS and Rhodium-Iron.

The PTC Sensor Configuration Menu is shown here.

The full-scale input resistance and the excitation level will change depending on the type of PTC sensor selected.

PTC sensor excitation can be either AC or DC. The Model 24C is calibrated with AC excitation. Switching to DC will introduce a DC offset that will result in temperature measurement errors.

When AC excitation is On, the sensor excitation current is a 7.5 Hz square wave. This square wave excitation generates a small noise signal. Rarely, this signal will be seen up by sensitive measurement equipment in the system. Turning AC excitation Off will eliminate this noise at the cost of introducing a DC offset measurement error.

ChA: Sample Holder		
PTC Sensor Configuration		
+	241.00K	FS Input: 500 Ohms
AC	Excitation: ON	Excitation: 1mA
		Pd: 1.66e-10W
Return to ChA cfg		

Using the Relays

The Model 24C has two relays that can be used to control external processes. Able to switch up to 10 Amperes, they can even be used with large solenoid valves or motors.

Relays can be configured for several modes of operation.

Auto is the basic way of setting the controller to assert a relay based on a high or low temperature setpoint. **Within** mode is the logical inverse of **Auto** mode in that it asserts the relay when a temperature measurement is within a high and low limit rather than outside of it. The **On** and **Off** modes simply assert or clear a relay under remote control and the **Control** mode asserts a relay whenever the controller is actively controlling temperature.

Relay status indicators are used to show the status of a relay. These indicators are the same when viewed on the front panel, the embedded web page or from a remote command. Additionally, there are two LEDs on the front panel that illuminate whenever their relay is asserted.

Relay Configuration

Relay configuration can be done from the front panel, the embedded web server or by using remote commands.

From the front panel, the Relay Configuration Menu is used to configure individual relays. To access the menu,

press the Options key and then select Relay 1 or 2.

Here, the relay Source input may be selected as any of the input channels and the Mode field controls relay operation. The Deadband

field sets the amount of hysteresis applied to the temperature measurement before a relay is toggled.

Relay Modes	
Auto	Relay is controlled by enabled high and low setpoints.
Within	Inverse operation of Auto mode. Used for fail-safe configurations.
ON	Relay is in manual mode and is asserted.
OFF	Relay is in manual mode and is clear.
Control	Relay is asserted whenever the controller is in Control mode.

Table 23: Relay Modes

Relay Status Indicators	
--- or OFF	Relay is not asserted
HI	Asserted by a high temperature condition.
LO	Asserted by a low temperature condition.
ON	Asserted.

Table 24: Relay Status Indicators

```

Relay 1 Configuration Menu
Source: ChA:Fail Safe
SourceTemp:294.80K  Rly Status: ON
Mode: Within        Deadband: 0.25
High: 250.00        Low: 220.00
High Enable: Yes    Low Enable: Yes

```

As an example, if the deadband is set to 0.25K, a high temperature relay condition will not assert until the input channel's temperature exceeds the setpoint by 0.25K and will not clear until the temperature drops back to 0.25K below the setpoint.

Relay Auto Mode

Auto mode is used to implement simple high and low setpoint operation. Setting a relay to assert on a high temperature condition requires setting Auto mode, setting a high setpoint then enabling the high setpoint. Similarly for a low setpoint, the low setpoint must be enabled and set.

Example: To assert a relay when a temperature measurement exceeds 330K or drops below 250K, set the **Mode** field to Auto, the **High** field to 330, the **High Enable** to Yes, the **Low** field to 250 and the **Low Enable** to Yes.

Assuming a deadband of 0.25K, the relay will assert high at 330.25K and clear at 329.75K. It will also assert low at 249.75K and clear again at 250.25K.

Relay Within Mode

The Within is the logical complement of Auto mode. This will assert a relay when the input temperature is within a window.

The primary use of Within mode is to implement a fail-safe function. Here, the relay will only be asserted when an input temperature reading is both valid and within the high and low setpoints. Presumably, the process being monitored would only continue to function when the relay is asserted.

To set a fail-safe function, the user must a) Set the Mode to Within, b) Set both the high enable and low enable to Yes and c) Set a window by entering a high and low setpoint.

Example: To set a fail-safe function that asserts a relay when the input temperature is valid and within the range of 250K to 310K, do the following:

- Set the relay **Mode** to Within.
- Set both the **high** and **low enables** to Yes.
- Set the **High Setpoint** to 310K and the **Low Setpoint** to 250K.

Relay Control Mode

The relay Control mode asserts a relay when the controller is actively controlling temperature. It's primary use is with a booster power supply connected to control loops #3 and #4. Here, the relay can be used to turn on AC power to the booster supply only when it is needed. The desirable result is that the booster supply will be turned off when it is not being used so there will be no leakage power or noise driven into the user's system.

Relay ON and OFF Modes

The ON and OFF modes manually assert or clear a relay. They are primarily used during remote control. For example, the remote command that turns relay #1 ON is:

RELAY 1 : MODE ON

Installing Custom Sensor Calibration Curves

Downloading a Sensor Calibration Curve

The Model 24C accommodates up to eight user-defined sensor calibration curves that can be used for custom or calibrated sensors. Since these curves have up to 200 entries, they are usually maintained on a computer as a text file and downloaded to the controller by using the Cryo-con Utility Software provided with the instrument. However, curve data may also be entered and edited from the front panel.

Cryo-con sensor calibration curves have a file extension of .crv. They may be opened and edited with any text editor. The format of the file is detailed in [Appendix A](#).

The process for downloading a sensor calibration curve using the Cryo-con utility software is detailed in the section titled [Downloading or Uploading a Sensor Calibration Curve](#). This section discusses how to set up a curve specifically for download to the Model 24C.

The Cryo-con utility software will read and attempt to parse the following file types:

Sensor Curve File Types	
Cryo-con .crv	Directly supported.
Lakeshore .340	Supported. Reads curve data. Header information must be entered by using the header dialog box. The Cryo-con utility software will convert these files into .crv format automatically.
SI .txt	No header information. Columns are reversed from other formats. Must be manually converted to a .crv file before use.
Other .txt	Software will attempt to parse any text file. If the file contains columns of sensor readings vs. temperature, the entries will be properly parsed and the curve can be used or converted to a .crv file after the header dialog box is filled out.

In order to download a file, run the utility software and select 'Sensor Curve Download'. The user will be prompted to select a file. Once the software has read the file, the header information dialog box will appear.

The screenshot shows a dialog box titled "Edit Curve Header:" with the following fields and controls:

- Sensor Name:
- Sensor Type:
- Multiplier:
- Unit:
- Number of Pts:
- Buttons: Accept, Abort, Display Curve
- Checkbox: Save as .crv file

The Sensor Name can be any string, up to 15 characters, that helps identify the sensor. The Sensor Type, Multiplier and Unit fields affect how the instrument is configured, so they must be correctly set or unexpected results will be obtained.

Sensor	Type	Multiplier	Units	Example
Cernox™	ACR	-1.0	LogOhms	CX1030E1.crv
Ruthenium-Oxide	ACR	-1.0	LogOhms	LSRX102.crv
Thermistors	ACR	-1.0	LogOhms	LSRX102.crv
Rhodium-Iron 27Ω	PTC100	1.0	Ohms	rhfe27.crv
CLTS-2B	PTC 1K	1	Ohms	CLTS-2B
Germanium	ACR	-1.0	LogOhms	LSRX102.crv
Carbon Glass	ACR	-1.0	LogOhms	LSRX102.crv
Silicon diode	Diode	-1.0	Volts	s900diode.crv
Carbon Ceramic	ACR	-1.0	LogOhms	LSRX102.crv
Platinum 100Ω	PTC100	1.0	Ohms	PT100385.crv
Platinum 1KΩ	PTC1K	1.0	Ohms	PT1K385.crv
GaAlAs diode	Diode	-1.0	Volts	s900diode.crv

Table 25: Recommended Sensor Configuration Data

Note that NTC resistor data is generally in units of LogOhms. However, it can also be in units of Ohms. Be sure to check the curve data for reasonableness.

① Note: One simple way to generate a sensor calibration curve is to open a similar sensor file with a text editor and paste in your own data. The example files in the above table are for that purpose. They are located crv_files sub-directory of the Cryo-con utility software package. For NTC thermistors, try the AB270.crv file, for Diodes the S900.crv file and PTC RTDs use the PT100385.crv.

At this point, it is a good idea to view a graph of the curve data.

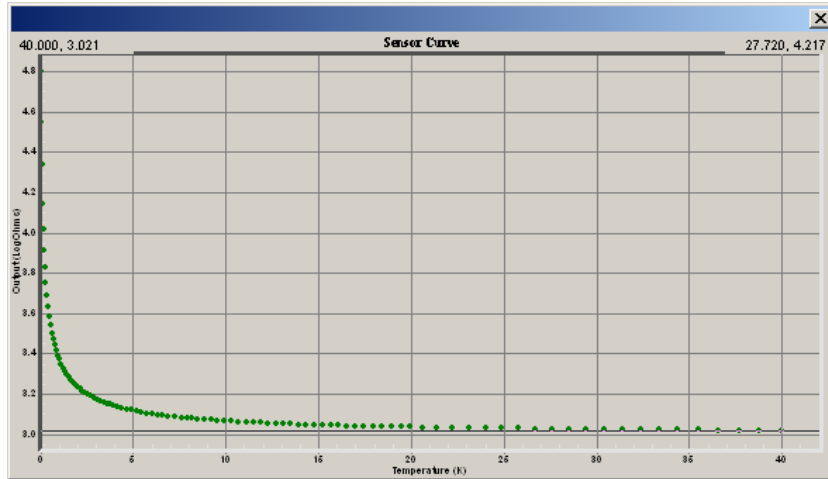

The above graph is for a Ruthenium-Oxide sensor with units of LogOhms. It shows the typical highly non-linear curve for that type sensor. If the curve data was in units of Ohms, it would be so extremely non-linear that significant errors might result.

Check the graph for reasonableness and then dismiss it.

Proceed with downloading the curve to the instrument. Once complete, check and verify the result. The curve may be uploaded from the controller by using the Operations>Sensor Curve>Upload function of the utility software. Or it may be manually checked from the controller's front panel by pressing the **Sensors** key.

Assigning a custom curve to an input channel.

To assign your downloaded curve to a specific input channel, go to the Input channel Setup menu, scroll to the Sen: field and change the sensor to the user curve you have installed. The name you used on the first line of the file will be displayed as the sensor name.

Downloading a PID table

PID tables are uploaded or downloaded by using Cryo-con Utility Software. To download a PID table, open the utility and connect to the controller. Then, click PID Table Download in the Short Cuts bar. Next, select the desired PID table .txt file and click Open. In the dialog box, select the desired PID table number to download and click on OK. This will read and install the selected table.

To use the table with a control loop, go to the Outputs page and scroll down to the desired control loop. Then, select the desired PID table from the PID Table drop-down box.

PID tables may also be entered or viewed on the Model 24C front panel by pressing the PID Table(8) key.

The PID table may also be selected on the front panel by going to the Control Loop Configuration menu.

PID Table Format

There is a maximum of 16 entries in each PID table. Each entry contains a setpoint, P, I and D coefficients, a heater range and an input channel. Usually, the input channel is set to the value of Default to select the input source channel of the control loop.

The file format of a PID table is shown below:

```
<name>
<entry 0>
<entry 1>
*
*
*
<entry N>
;
```

Where:

<name> is the name of the table and is a maximum of 16 ASCII characters.

<entry> is a PID entry.

A line that contains only a single semicolon indicates the end of the table.

The format of an entry is:

<Setpt> <P> <I> <D> <range> <Source>

Fields are separated by a white space. The entry is terminated by a new line (\n) character.

<Setpt> <P> <I> <D> are floating-point numbers that correspond to Setpoint, Pgain, Igain and Dgain.

<range> is the heater range string. For Loop 1, choices are:

HI | MID | LOW. For Loop 2, they are: **HI | LOW**.

<Input Channel> is the controlling source input channel and may be ChA, ChB, ChC, ChD or Default. Note that default selects the input channel from the control loop's source setting.

Floating point numbers may be entered with many significant digits. They will be converted to 32 bit floating point, which supports about six significant digits.

An example of a sixteen entry PID Table is as follows:

```

PID Test 0
300.00  1.60  160.00  40.00  HI  Default
280.00  1.50  150.00  30.00  HI  Default
260.00  1.40  140.00  30.00  HI  Default
240.00  1.30  130.00  30.00  HI  Default
220.00  1.20  120.00  30.00  HI  Default
200.00  1.10  110.00  20.00  HI  Default
180.00  1.00  100.00  20.00  MID Default
160.00  0.90   90.00  20.00  MID Default
140.00  0.80   80.00  20.00  MID ChB
120.00  0.70   70.00  10.00  MID ChB
100.00  0.60   60.00  10.00  MID ChB
 80.00  0.50   50.00  10.00  MID ChB
 60.00  0.40   40.00  10.00  LOW ChA
 40.00  0.30   30.00   0.00  LOW ChA
 20.00  0.20   20.00   0.00  LOW ChA
 10.00  0.10   10.00   0.00  LOW ChA
;

```

Entries may be sent to the controller in any order. Entries containing invalid numeric fields will be deleted.

Note: There is a PID table example file, PIDtbl0.txt on the Customer CD in the Sensors→crv_files sub directory. It may be easiest to edit your own values into this example.

Autotuning

The Autotune Process

In performing autotuning, the Model 24C applies a generated waveform to the heater output and analyzes the resulting changes in process temperature. This is used to develop a process model, then a PID solution.

It is important to note that a range of PID combinations exist, which provide accurate control for a given process. Furthermore, process modeling is a statistical method affected by noise and system non-linearity.

Consequently, multiple autotuning of the same process may yield different results. However, if the process model has not corrupted, any of the generated results will provide equally stable temperature control.

For further explanation, the different PID solutions generated by autotuning vary only in the resultant closed loop bandwidth. Low bandwidth solutions are slower to respond to changes in setpoint or load disturbances. High bandwidth solutions are responsive but can exhibit overshoot and damped oscillation.

The Model 24C attempts to generate minimum overshoot solutions since many cryogenic temperature control applications require this. If the process is noisy, bandwidth is minimized as much as possible. If the process is very quiet, a more aggressive solution is generated subject to the minimum overshoot requirement.

The autotune algorithm produces a heater output waveform in order to force the process model to converge. In general, a large amplitude waveform will provide the best possible signal-to-noise ratio, resulting in a faster and more accurate solution.

However, it is important in some systems for the user to constrain the amplitude and duration of the heater output waveform by using the DeltaP and Timeout parameters.

Small values for DeltaP force the use of small changes in heater power. This makes the process model more susceptible to corruption by noise.

Large values of DeltaP will allow the use of large heater power swings, but this may also drive the process into non-linear operation, which also corrupts the tuning result. Worse, it may allow the application of too much heater power, which causes an over temperature condition.

Experience indicates that most cryogenic systems autotune properly using a DeltaP of 5% whereas a noisy system requires 10% or more. A common example of a noisy cryogenic system is one where a Silicon diode sensor is used with a setpoint near room temperature.

System Noise and Tuning Modes

Three modes of autotuning may be selected. They are: P only, PI and PID.

Using P only autotuning gives the maximum value for P that will not cause oscillation. The process temperature stabilizes at some point near the setpoint.

Using PI or PID control results in stable control at the setpoint.

The Derivative, or D, term in PID is used to make the controller more responsive to changes in setpoint or thermal load. It does not affect the control accuracy when the system has stabilized. However derivative action, by its nature, amplifies noise. Therefore, PID autotuning and control should only be used with very quiet systems. PI control should be used with all others.

Sensor type has a significant impact on measurement noise.

The Model 24C uses a ratiometric technique to measure resistor sensors such as Thermistors, Platinum RTDs, Carbon Glass etc. This effectively cancels most of the measurement noise and allows effective use of PID control.

Voltage mode sensors, which include diodes and thermocouples, cannot benefit from ratiometric measurement, therefore, PI control is recommended.

It is a very common mistake to attempt PID control using a diode sensor above 70K. This is the least sensitive region of the sensor so measurement noise is very high. PI control is recommended.

Below about 20K, the sensitivity of the diode increases significantly and PID control may be used effectively.

Pre-Tuning and System Stability.

Before autotuning can be initiated by the controller, the system must be stable in terms of both temperature and heater output power. This requires the user to perform a basic pre-tuning operation before attempting the first autotune.

The goal of pre-tuning is to stabilize the process at a temperature near the desired setpoint so that the tuning algorithm can use this as a baseline to model the process.

Cryogenic systems will usually require different PID values at different setpoint temperatures. Therefore, the pre-tuning process should result in a temperature near the desired setpoint.

Pre-tuning does NOT require that the user establish stable control at the target setpoint. This is the job of the autotuning algorithm and is much more difficult than the stability required by pre-tuning.

One method of pre-tuning is to use PID control with a small initial value for P and zero for I and D. This will result in stability at a temperature of the setpoint minus some constant offset. Increasing the P value reduces the offset amount. When P is too large, the system oscillates.

Another pre-tuning technique is to Manual control mode with some fixed value of output power. When the system becomes stable at a temperature corresponding to the set heater power level, a system characterization process is performed using that temperature as an initial setpoint.

System Characterization.

System characterization is the process of using autotune to generate optimal PID coefficients for each setpoint over a wide range of possible setpoints.

The characterization process is performed once. Then, the setpoints and corresponding generated PID values are transferred to an internal PID table. Thereafter, the system is efficiently controlled using the Table control mode.

Autotune Setup and Execution

The Autotune menu for either control loop is accessed by pressing the **Auto Tune** key from the Home Operate Screen.

Upon entry, the autotune state variable is set to Idle and the P, I and D fields on the bottom of the display will be blank.

As described above, various setup conditions must be met before autotune can be performed:

1. The Model 24C must be in Control mode.
2. Both the output power and the process temperature must be stable. The user must stabilize the process before the autotune function can accurately model it. If the process is not stable, erroneous values of P, I and D will be generated.
3. The input control channel units must be in temperature, not sensor units of Volts or Ohms. This is because PID control is a linear process and sensor output is generally non-linear. Note that the Model 24C can be manually tuned using sensor units but autotuning cannot be performed.

Autotune Menu	
+Autotune: Loop 2	Sets the loop number for autotuning. Each control loop must be tuned separately.
#DeltaP: 20%	Sets the maximum power delta allowed during the tuning process. Value is a percent of full-scale output power.
+Mode: PI-	Sets autotuning mode. Choices are P, PI or PID.
#Timeout: 180S	Sets the autotune timeout in seconds. If the process model has not converged within this time, tuning is aborted.
308.112K	Real-time display of the temperature on the input channel being tuned.
•GO	Pressing Enter will initiate the autotune sequence.
Idle	Autotune status. Display only
P=	Proportional gain term generated by autotune. This field will be blank until a successful autotune is completed.
I=	Integral gain term generated by autotune. This field will be blank until a successful autotune is completed.
D=	Derivative gain term generated by autotune. This field will be blank until a successful autotune is completed.
•Save & Exit	Pressing Enter cause the controller to transfer the generated PID coefficients to the selected loop, initiate control with the new parameters and exit to the Home Operate Display.

Table 26: Autotune Menu

The Delta P field is in percent and is the maximum change in output power that the controller is allowed to apply during the modeling process. A value of 100% allows use of full-scale power increments. A value of 20% uses a maximum power increment of $\pm 20\%$ of the current heater output.

The Mode field tells autotune to generate coefficients for P only, PI only, or PID. Choices are: P--, PI- and PID.

The Timeout field is in units of Seconds and indicates the maximum period of time that the process model will run before aborting. This value should be set to at least two or three times the estimated maximum time constant of the process.

ⓘ Note: Depending on the setup configuration, the autotune algorithm may apply full-scale heater power to the process for an extended time. Therefore, care should be taken to ensure that autotune does not overheat user equipment. If overheating is a concern, the Over Temperature Disconnect Monitor should be configured to disconnect the heater and abort the autotune process when an input temperature exceeds the specified maximum.

The autotune sequence is initiated by selecting the Go field. If the initialization of process modeling is successful, the status display line will change from idle to Running. If initialization is not successful, one of the above listed conditions has not been met.

State	
Idle	Idle.
Stabilize	Waiting for input temperature and output power to stabilize.
Running	Actively autotuning.
Complete	Successful completion.
Failed	Failed due to processing error. Usually, this is because the process model did not converge. Try a smaller DeltaP setting.
Abort	Aborted by the user.

Table 27: Autotune States

ⓘ Note: When autotuning is initiated, the algorithm will stay in the 'Stabilize' state until the output power and the input temperature are stable. Time in this state is not part of the selected timeout. If the system is not stable, the autotuning process will stay in the Stabilize state indefinitely. To abort, press the **Home** key.

When the tuning process is successfully completed, a status of Complete will be indicated and the values of P, I and D will be updated with the generated values. To accept these values and save them as the loop PID coefficients, select the Save&Exit field. To reject the values and exit, press the **ESC(▼)** key.

Autotune may always be aborted by pressing the **ESC(▼)** key.

An unsuccessful autotune is indicated by one of the following status lines:

1. Failed. This indicates that the process model did not converge or that PID values could not be generated from the result.
2. Aborted. Autotune was aborted by user intervention such as pressing the Stop key.

Temperature Ramping

Operation

The Model 24C performs a temperature ramp function using a specified ramp rate and target setpoint. Once placed in a ramping control mode, a ramp is initiated by changing the setpoint. The unit then progresses to the new setpoint at the selected ramp rate. Upon reaching the new setpoint, ramp mode is terminated and standard PID type regulation will be performed.

Ramping may be independently performed on control loop.

The procedure for temperature ramping is as follows:

1. Set the Ramp Rate in the Heater Configuration Menu. This parameter specifies the ramp rate in Units Per Minute, where Units are the measurement units of the input channel controlling the heater. For example, if the input channel units are Kelvin, the ramp rate is in K/min.
2. Select the ramping Control Mode, RampP.
3. Press CONTROL. Now, the controller will begin temperature regulation at the current setpoint.
4. Enter a new setpoint. The controller will enter ramping mode, and ramp to the target setpoint at the specified rate.
5. When the new setpoint is reached, ramping mode terminates and temperature regulation will begin at the new setpoint.
6. Entry of a different setpoint will initiate another ramp.

As a variation on the above procedure:

1. The controller may be regulating temperature in any available control mode. This mode can be changed to a ramping mode without exiting the control loop. This will not result in a 'glitch' in heater output power.
2. Once a ramp mode is selected, ramping is performed, as above, by changing the setpoint.

The current status of the ramp function may be seen on the Operate Screen. When a ramp is active, the word RMP will appear in the control loop status displays. It may also be queried via any of the remote ports using the LOOP 1:RAMP? Command.

Ramping Algorithm

The ramp algorithm uses a basic PID type control loop and continuously varies the setpoint until the specified temperature is reached. This means that the PID control loop will continuously track the moving setpoint. The result is that there will be small time lag between the target ramp and the actual temperature.

Although not normally a problem, the ramp time lag may be minimized by using aggressive PID values. This is accomplished by increasing P, decreasing I and setting D to zero.

Ramping Parameters and Setup

The Ramp Rate is set on the Control Loop Setup menu. Note that the ramp rate on Loop 1 is independent of the rate on Loop 2.

Ramping Example

First, the controller must have PID tuning values that give stable temperature control at both the beginning and end of the ramp. The PID values are usually 'slow' (Low values for P, high for I and zero for D). The actual values are not critical, they just need to give stable control.

Next, set the control type to RampP and set the desired ramp rate in the Heater Configuration Menu. Then set the loop setpoint to the *starting* value for the ramp.

The best way to view a temperature ramp is from the control loop status. Press Loop 1 key to view a screen like this:

Here, the instrument is not controlling temperature and the ramp will start at 180K.

```

Loop 1A: Sample Holder
Set Pt: 180.000K      A: 175.234K
Pgain: 5.0000        1-Off-Low -Htr-Off
Igain: 120.00S
Dgain: 0.0000/S      Range: HI
Pman: 5.0000%        PID Table index: 1
Type: RampP          Htr Load: 50Ω
Input: ChA           Next

```

When the **Control** button is pressed, the controller will go to the setpoint and control temperature there. It is NOT yet ramping! The display will look like this:

```

Loop 1A: Sample Holder
Set Pt: 180.000K      A: 180.000K
Pgain: 5.0000        51% HI ***---|
Igain: 120.00S
Dgain: 0.0000/S      Range: HI
Pman: 5.0000%        PID Table index: 1
Type: RampP          Htr Load: 50Ω
Input: ChA           Next

```

Controlling at 180K but NOT ramping

Now, you can begin ramping by changing the setpoint to the *end* of the ramp. The display will indicate that a ramp is in-progress. In this example, the setpoint was changed to 190 and the controller is ramping from 180.000. Notice that the loop status area now indicates a ramp is in progress. The Ramp Pt: field shows where the ramp should be and is

continuously updated until the new setpoint is attained. The input temperature should track the Ram Pt: field, indicating that the ramp is progressing as it should.

```

Loop 1A: Sample Holder
Set Pt: 190.000K      A: 181.234K
Pgain: 5.0000        Ramp HI ***---|
Igain: 120.00S       Ramp Pt: 181.110
Dgain: 0.0000/S      Range: HI
Pman: 5.0000%        PID Table index: 1
Type: RampP          Htr Load: 50Ω
Input: ChA           Next

```

Ramping to 190K

Ramping will continue until the setpoint is attained. Then, the loop status will return to normal PID control and the controller will maintain the setpoint.

From here, each time you change the setpoint, the controller will ramp to the new value and control temperature there.

```

Loop 1A: Sample Holder
Set Pt: 190.000K      A: 190.000K
Pgain: 5.0000        58% HI ****--|
Igain: 120.00S       Range: HI
Dgain: 0.0000/S      PID Table index: 1
Pman: 5.0000%        Htr Load: 50Ω
Type: RampP          Next
Input: ChA

```

Ramp complete. Controlling at 190K

Summary

To perform a temperature ramp, proceed as follows:

1. Set the control loop P, I and D parameters to allow stable control at both ends of the desired ramp. This is usually done by using 'slow' PID values (Low values for P, high for I and zero for D).
2. Set the Ramp Rate in the Heater Configuration Menu. Set the setpoint to the starting value for the ramp.
3. Press CONTROL. Now, the controller will begin temperature regulation at the current setpoint.
4. Enter a new setpoint. The controller will enter ramping mode, and ramp to the target setpoint at the specified rate. The word RMP will appear in the control loop menu.
5. When the new setpoint is reached, ramping mode terminates and temperature regulation begins at the new setpoint.

Using Temperature Alarms

The Model 24C monitors provide programmable temperature alarms on each input channel. High and low temperature alarms may be entered and enabled.

Alarm conditions are indicated on the front panel by the Alarm LED and various display fields. They are also reported via the remote interfaces.

Alarm Status Indicators	
---	No alarm.
HI	Asserted by a high temperature condition.
LO	Asserted by a low temperature condition.
	A latched alarm is indicated by appending the letter L to the status indicator.

Table 28: Alarm Status Indicators

When the audible alarm is enabled, a buzzer will sound whenever an alarm is asserted.

Latched alarms are also supported. These must be manually cleared as they remain asserted even after the condition that caused them has been cleared.

Note: To clear a latched alarm, press any of the keys on the front panel.

Alarm Configuration

Alarm configuration can be done from the front panel, the embedded web server or by using remote commands. From the front panel, the Input Channel Setup Menu is used. This is accessed from the Home menu by pressing the **Enter** key and then selecting an input channel for the alarm.

Basic configuration is done by entering a setpoint and then enabling the desired alarm. The Deadband field sets the amount of hysteresis applied to the temperature measurement before an alarm is toggled.

As an example, if the deadband is set to 0.25K, a high temperature alarm will not assert until the input channel's temperature exceeds the setpoint by 0.25K and will not clear until the temperature drops back to 0.25K below the setpoint.

From this menu, latched and audio alarms can also be set.

Setting an Ambient Temperature Alarm

The sensor type 'Internal' reads an internal temperature sensor located near the instrument's primary voltage reference. This measurement should read slightly above ambient temperature and is useful to track variations in ambient temperature for correlation with external events. It can also be used to set alarms for when the ambient temperature is outside the range where your measurements are at specified accuracy.

To configure an ambient temperature alarm, set the sensor type to Internal and then proceed as with any other alarm.

Using the Non-powered Control Loops

External Booster Supplies

Control loop Configuration

Some systems require more power than the Model 24C's control loops can provide. An external DC power supply or amplifier can often be used for this purpose.

The non-powered control loops #3 and #4 are designed to drive supplies that can be programmed by an input voltage. Two ranges of 5V or 10V are provided to match the inputs of most common supplies. Further, either of the Model 24C's relays can be used to turn the supply's AC power on or off.

```

      Loop 3D:Oven
Set Pt:220.000K      D: 211.234K
Pgain: 5.0000      3-Off-Low -Htr-Off
Igain: 60.000S
Dgain: 7.5000/S      Range: 10VDC
Pman: 5.0000%      PID Table index: 1
Type: PID      Htr Load: N/A
Input: ChD      Next
  
```

To configure the Model 24C for use with an external booster supply, go to the loop #3 or #4 configuration menu (Options->Control Loop x) and select the voltage range that matches your supply's input requirements and then set the desired control configuration just as you would for any of the control loops. In the above example, the control type is set to PID, but all of the types available on Loops #1 and #2 are also available.

Next, connect the Model 24C's loop #3 or #4 output to the programming voltage input of your supply.

Controlling AC Power to the External Supply

In many cases, it is desirable to completely disconnect the external booster supply from its AC power while it is not actively controlling temperature. This eliminates electrical noise that may be output by the supply during normal operation.

The Model 24C's relay outputs can be configured to turn the external supply on or off depending on the state of its control mode. When actively controlling temperature, the selected relay will be asserted ON and when control is inactive, the relay is OFF. To configure a relay for booster supply control, go to the relay configuration menu (Options->Relay x) and select a Mode of Control.

```

      Relay 1 Configuration Menu
Source:ChC:Oven
SourceTemp:273.268K  Rly Status: OFF
Mode: Control      Deadband: 0.25
High: 200.00      Low: 100.00
High Enable:No      Low Enable: No
  
```

Power supplies designed for Automatic Test Equipment (ATE) usually have a remote on/off capability that can be controlled directly by one of the Model 24C's relays. In cases where the relay is connected directly in series with AC power, be sure to observe the relay's 10A contact rating.

Using CalGen

The CalGen feature is used to generate new calibration curves for Silicon diode, thermocouple or Platinum sensors. This provides a method for obtaining higher accuracy temperature measurements without expensive sensor calibrations.

Most Cryo-con temperature controllers support CalGen directly on the instrument. However, the utility software package implements the same algorithm and can be used with virtually any instrument capable of measuring temperature.

Curves can be generated from any user selected sensor calibration curve and are written to a specified internal user curve location.

For diode sensors the user may specify one, two or three data points. CalGen generates the new curve based on fitting the input curve to the user specified points.

Platinum or thermocouple calibration curves require one or two data points. The generated curve is a best fit of the input curve to the two specified input points.

Since CalGen fits a sensor calibration curve to measured data, any errors in the measurement electronics are also effectively canceled.

Note: CalGen is re-entrant. Therefore, the user can enter or exit the CalGen menus at any time without loss of previously captured data points. For example, a data point may be captured near 300K, next, the user may exit the CalGen process in order to stabilize the controller near 77K. When the CalGen menu is re-entered for curve generation, the point captured at 300K is still valid.

CalGen Initial Setup

Generation of a calibration curve using CalGen requires the measurement of various temperature points. Therefore, an input channel must be configured with the correct sensor before the CalGen process can start.

To initiate the curve generation, select the CalGen field on the Input Channel Setup menu. This takes the screen to a sub-menu for the specific sensor type.

Note: Before CalGen can be initiated, there must be a valid temperature reading on the selected input channel. If this is not the case, selecting the CalGen field will cause the display of an error message.

When the input channel has a valid reading, CalGen determines if the sensor is a diode or Platinum sensor. The calibration curve of the selected input sensor is used as the input to the curve generation process.

Using CalGen With Diode Sensors

Options for generating diode calibration curves are:

1. One point near 300K. The portion of a diode Sensor curve above 30K is fit to a user-specified point near 300K. This is a two-point fit where the 30K point is taken from the existing calibration curve. The portion of the curve below 30K is unaffected.

2. Two points: 300K and 77K. Here, two user-specified points are taken to fit the diode curve region above 30K. The entire curve is offset to match the 77K point, then, the >30K region is fit to the two points.
3. Three points: 300K, 77K and 4.2K. Two points above 30K are fit as in the selection above. Then, a third point is used to fit a single point in the high-sensitivity region below 20K.
4. One point near 4.2K. This is a two-point fit where the 20K point is taken from the existing calibration curve. The portion of the curve above 20K is unaffected.

For a diode sensor, a sub-menu is displayed that allows the user to select the number of points desired for the CalGen fit.

First CalGen Menu, Diode Sensor	
●1pt CalGen @300K	Pressing the Enter key will select curve generation with a single point near 300K.
●2pt CalGen	Pressing the Enter key will select curve generation at two points where both points must be > 50K.
●3pt CalGen	Pressing the Enter key will select curve generation three points: Two above 50K and one near 4.2K.
●1pt CalGen @4.2K	Pressing the Enter key will select curve generation with a single point near 4.2K.

Table 29: First CalGen Menu, Diode Sensor

From this screen, select the desired number of points. For example, select '2 point'. This will take the display to the two-point curve generator screen shown here.

CalGen Menu, 2-point Diode Sensor	
#300.000 Capture	The exact temperature at a point near 300K is entered here. Note: if CalGen has not been used on this channel before, the word Capture will appear. Otherwise, the last captured sensor reading will appear.
●Unit: 0.98257V	Pressing the Enter key will capture the existing unit reading and associate it with the 300K point. The value will be displayed on line 1 above.
#77.000 Capture	The exact temperature at a point near 77K is entered here.
●Unit: 1.28257V	Pressing the Enter key will capture the existing unit reading and associate it with the 77K point. The value will be displayed on line 3 above.
●New Curve	Pressing the Enter key will initiate the generation of a new curve.

Table 30: CalGen Menu, 2-point Diode Sensor

The two temperature points, one near 300K and the other near 77K may be entered in any order.

To enter the 300K-point, change the field 300.000 to the exact required temperature. Then, allow the temperature measurement to stabilize. When the measurement is stable, select the Capture field next to the temperature field. This will cause the Model 24C to capture the sensor reading and associate it with the specified temperature.

When a sensor reading is captured, the actual reading will be displayed in place of the word Capture. Note that the user may capture a new reading by selecting this field again, even if it already contains a reading.

The Unit field of this screen will display the actual sensor reading in real time. This will allow the user to determine when the unit is stable at the required temperature.

Next, the second temperature must be entered in the same way as before.

When both temperature points have been entered, the user may select the New Curve field in order to generate the new curve. This will cause the display of a menu like the one shown here:

CalGen New Curve Menu	
# User Sensor 1	Sets the curve number for the generated curve. Numeric entry. Note: only the user curves can be written.
• --Save--	Pressing the Enter key will cause the generation of a new curve. The curve will be stored at the curve number specified on line 1.

Table 31: CalGen New Curve Menu

From this screen, the user must select the target user curve for the generated curve. Finally, select the Save field in order to generate the curve and store it in the selected user location.

Note: The CalGen process may be aborted by pressing the **ESC(▼)** or **Home** key.

Using CalGen With Platinum and Resistor Sensors

The calibration curve generation procedure for Platinum or Resistor sensors is the same as for the diode sensors described above. However, these curves are generated using two user specified points. Therefore, the selection of the number of points is not required.

Using Thermocouple Sensors (Type TC70)

Thermocouple temperature sensors offer an extremely wide range of operation. They can also be inexpensive and easy to install. However, devices used in cryogenic applications are often difficult to apply because they exhibit poor sensitivity at low temperature and are generally constructed with metals that are difficult to use. In order to obtain the best possible measurement accuracy, the recommendations given here should be carefully applied.

Installing the Thermocouple Module

All thermocouple sensors require the use of an optional Cryo-con external thermocouple module (4039-004). This module plugs into any sensor input channel of a Model 24C. Up to four modules can be installed on a single instrument and they can easily be added or removed at any time. They are powered by the Model 24C and perform amplification, cold-junction compensation, open sensor detection and connection to copper.



Figure 3: Thermocouple Module

Internal switches are used to select the cold junction compensation for specific types. Open the module and use the switches to select types K, E, T, AuFe 0.7% or off.

Module Configuration

Before a thermocouple module can be used, the thermocouple type must be set into the module's internal switches. This selects the cold-junction compensation method.

To access the switches, remove the cover by removing the two screws from the plastic cover.

The type is set by the four switches shown here. Settings are E, K or T, AuFe 0.7% and OFF. The Off setting disables cold-junction compensation. Select the type by sliding the proper switch to the right. Ensure that there is only one type selected.

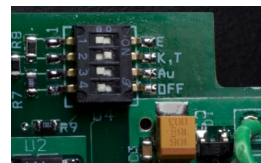

Figure 4: Thermocouple Switches

Next, replace the plastic cover on the module. The thermocouple module is now ready for use.

Instrument Setup

Instrument setup is performed as follows:

1. Connect the thermocouple module to any of the available input channels.
2. From the front panel, go to the Input Channel Configuration menu by pressing the appropriate **ChA** or **ChB** key. Next, scroll down to the Sen: field and select the sensor by pressing the **Next** key. When the proper thermocouple type is displayed, press the **Enter** key.
3. Scroll down to the Input Config field and press the Enter key to display the Thermocouple Sensor Configuration Menu.
4. Optionally perform the offset calibration procedure described below.
5. Return to the Home screen by pressing the **Home** key several times.

Offset Calibration

Thermocouple devices can vary significantly from their standard curves, especially at cryogenic temperatures where their sensitivity is reduced. To accommodate these variations, the Model 24C allows an offset calibration for individual thermocouple devices. Note that device calibration do not affect the instrument's basic calibration.

Device calibration is performed by using the instrument's Input Configuration menu. An example is shown here. Alternatively, calibration may be performed by using remote commands.

ChA: Radiation Shield	
Thermocouple Sensor Configuration	
+ 78.12K	FS Input: 70mV
Set Reading: 0.00K	
Return to ChA cfg	

This menu is selected by pressing the ChA key and then setting the Sensor field to the desired thermocouple type. Next, select the Input Config field.

For cryogenic applications, an offset calibration is usually done at a low temperature reference point. Examples being liquid nitrogen or even liquid helium. The result of the calibration is that the controller will read the correct temperature when the sensor is held at that reference. Setting the Reading field to zero turns offset calibration OFF. This is useful to start a new calibration.

Since thermocouples lose sensitivity at low temperature, an offset calibration in that range will generally have little effect on the higher temperature accuracy.

An offset calibration is done as follows:

1. Connect the controller as usual for thermocouple measurements. For best accuracy, be sure that ambient temperature doesn't vary.
2. Allow the instrument to warm up for at least ½ hour without moving or handling the sensor.
3. From the instrument front panel, first set the thermocouple sensor and then go to the input configuration menu.
4. Establish the thermocouple device at a precisely known temperature. When stable, enter the desired reading in the Set Reading field and press **Enter**. For example, if the sensor is immersed in liquid nitrogen, enter a value of 77.35K
5. The input temperature reading should now stabilize at the value entered.

Note that the Set Reading temperature is always in units of Kelvin.

Thermocouple Device Installation

The thermocouple device must first be connected to a standard thermocouple mini-spade connector of the proper type. Wires are attached using the screw terminals. Polarity is marked on the input connector and a summary of common thermocouple types is given in the table below. The input connector should have its plastic back-shell and rubber grommet installed in order to prevent local air currents from generating errors in the cold junction circuitry.

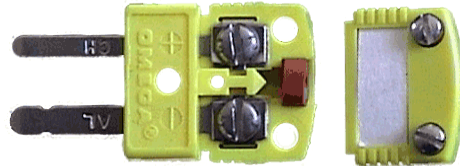

Type	Connector Color	(+) Terminal	(-)Terminal
E	Purple	Chrome Purple	Constantan Red
K	Yellow	Chrome Yellow	Aluminum Red
T	Blue	Copper Blue	Constantan Red
Chromel- AuFe	White	Chromel Silver	Gold Gold

Table 32: Thermocouple Polarities

Note that the Chromel-AuFe device is a special cryogenic device. The connector used is White, indicating a type U (unspecified) device.

Grounded vs. Floating Thermocouples

Electrically floating devices are always recommended because they provide generally lower noise operation and cannot facilitate ground-loop conditions. However, the thermocouple module inputs are differential and have a high impedance to ground. This will allow operation with grounded devices in most systems. Always ensure that there is no more than a 5V difference between the grounded thermocouple and the instrument's chassis ground.

Common Installation Issues

Cold Junction Compensation

Cold Junction Compensation in the Cryo-con thermocouple module is performed by a circuit that measures the temperature of the input connector pins. This reading is then used offset the device's output voltage. Errors can be minimized by reducing local air currents around the module.

Device Calibration Errors

Variation in the manufacture of thermocouple wire and its annealing over time can cause errors in temperature measurement.

Instruments that measure temperatures above about 0°C will usually allow the user to correct calibration errors by adjusting an offset in order to zero the error at room temperature. Unfortunately, in cryogenic applications, thermocouples lose sensitivity at low temperatures so a single offset voltage correction is insufficient.

Thermocouples used over a wide temperature range may need to be calibrated at two temperature extremes.

AC Power Line Noise Pickup

AC power noise pickup is indicated by temperature measurements that are significantly in error. In extreme cases, there may be no valid measurements at all.

When a grounded sensor is used, a poor quality ground may have sufficient AC voltage to exceed the input range of the module. This can often be corrected by running a copper connection from a point near the sensor ground and the chassis ground of the controller. Defective building wiring or insufficient grounding is usually the root cause.

General recommendations to minimize AC pickup include:

1. Minimize the length of the thermocouple wires. Connect the module as near as possible to the sensor so that thermocouple wires are converted to copper as soon as possible.
2. Twist the wires.
3. Avoid running sensor wires near, or parallel to AC power lines.

Restoring Factory Defaults

Factory default settings may be restored with the following simple procedure:

1. Turn AC power OFF by pressing the **Power** key.
2. Press and hold the Enter key while turning AC power back ON. Keep the key pressed until you see the power-up display indicating that defaults have been restored.

ⓘ NOTE: Factory defaults may be restored at any time by use of the following sequence: 1) Turn AC power OFF. 2) Press and hold the **Enter** key while turning power back ON. This sequence will restore factory defaults including resetting user supplied sensor calibration curves and saved user configurations. However, it will NOT erase the instrument's internal calibration data.

Shielding and Grounding

The Model 24C supports a single-point grounding scheme to prevent ground loops and low frequency power-line noise pickup.

A single-point-ground scheme starts with the establishment of a good quality ground point somewhere in your system. All components of the system, including the cryostat and connected instruments, should have a direct low impedance connection to this point.

In many systems, the ground point can be the third-wire-ground connection of the AC power outlet. If your facility does not provide a good quality ground in it's AC power distribution scheme, it is strongly recommended that one be fabricated. Noise pickup and ground loop problems are usually traced to how this connection is made.

To minimize RFI noise pickup, The Model 24C implements a shielding scheme that allows the construction of a complete shield around the instrument and cryostat. The instrument's enclosure is all Aluminum with wide conductive overlaps on all mating surfaces. Connecting cable shields to this enclosure on one end and to the cryostat on the other completes a continuous shield, thus forming a Faraday Cage RFI shield around the entire system.

In order for the instrument's grounding and shielding scheme is working effectively:

1. All sensors and heaters must be electrically floating with respect to ground.
2. The instrument side of all sensor cable shields must be connected to their connector's metal back-shell. Heater cables should have their shields connected to the chassis ground lug.
3. At least one cable must have it's shield connected to the connector's back-shell on the cryostat end.
4. A good quality earth-ground point must be established. All instruments and the cryostat should have a direct connection to this point.

ⓘ Note: There is some possibility that a ground-loop will be formed when a sensor cable shield is connected at both the cryostat and instrument end. If this happens, it is recommended that the ground-loop first be fixed and then the connection be made. Ground-loops are usually fixed by properly implementing a single-point-ground scheme.

ⓘ Note: The Ethernet LAN interface is electrically isolated and cannot introduce ground loops.

Instrument Calibration

Calibration of the Model 24C controller requires the use of various voltage and resistance standards in order to generate calibration factors for the many measurement ranges available.

Calibration is 'Closed-Case'. There are no internal mechanical adjustments required. The Model 24C cannot be calibrated from the front panel.

Calibration data is stored in the instrument's non-volatile memory and is accessed only via the remote interfaces.

A calibration procedure document may be obtained by contacting Cryo-con technical support at CCTechSupport@cryocon.com.

Cryo-con Calibration Services

When the controller is due for calibration, contact Cryo-con for low-cost recalibration. The Model 24C is supported on our automated calibration systems which allow Cryo-con to provide this service at competitive prices.

Calibration Interval

The Model 24C should be calibrated at a regular interval determined by the measurement accuracy requirements of your application.

A 90-day interval is recommended for the most demanding applications, while a 1-year or 2-year interval may be adequate for less demanding applications. Cryo-con does not recommend extending calibration intervals beyond 2 years.

Whatever calibration interval is selected, Cryo-con recommends that complete re-adjustment should always be performed at the calibration interval. This will increase user confidence that the instrument will remain within specification for the next calibration interval. This criterion for re-adjustment provides the best measure of the instrument's long-term stability. Performance data measured using this method can easily be used to extend future calibration intervals.

Remote Operation

Remote Interface Configuration

The Model 24C has two remote interfaces: The Ethernet LAN and the RS-232. There are also two external options: IEEE-488.2 (GPIB) and USB. Connection to all of these interfaces is made on the rear panel of the instrument. For specifics about the connectors and cables required, refer to the section on Rear Panel Connections.

ⓘ Note: Maximum reading rate on remote interfaces is 10 readings per second.

Supported Ethernet Protocols

HTTP: The Model 24C's HTTP server is used to implement the instrument's embedded web server.

SMTP: The Simple Mail Transport Protocol is used to send E-mail from the Model 24C to a selected address.

TIMEP: The Time Protocol allows a client to obtain the date and time from a host TIMEP server. If a time server is available on the Local Area Network, the Model 24C will periodically query it to update its internal real-time clock.

TCP/IP UDP: These ports are available for communication using an ASCII command language.

Ethernet Configuration

The Model 24C is shipped with a default IP address of **192.168.1.5** and Subnet Mask of **255.255.255.0**. Using these settings, the instrument communicates with any computer or device that has an IP addresses in the range of 192.168.1.0 through 192.168.1.255. The user can configure the Model 24C to use any other IP address by going to the [Network Configuration Menu](#).

TCP/IP Data Socket Configuration

TCP/IP is a connection orientated protocol that is more complex and has higher overhead than UDP. The user must bind a TCP/IP socket and negotiate a connection before communicating with an instrument.

The default TCP/IP port address is 5000. This can be changed from the front panel by going to the [Network Configuration Menu](#).

UDP Configuration

UDP is a simple connection-less protocol that can be used to communicate with Cryo-con instruments. The user binds a UDP socket and communicates with the instrument in a fashion similar to the older RS-232 style communications.

UDP uses a port that is the TCP port address plus one. Therefore, the factory default is 5001.

IEEE-488 (GPIB) Option Configuration

The only configuration parameter for the optional GPIB interface is to set the address. This is done by using the [System Functions Menu](#) described above. Once the external GPIB interface is connected to the controller's LAN port, configuration is performed by the instrument.

Note that each device on the GPIB interface must have a unique address. Set the instrument's address to any value between 1 and 31. The address is set to 12 when the unit is shipped from the factory.

The GPIB interface does not use a termination character, or EOS. Rather, it uses the EOI hardware handshake method to signal the end of a line. Therefore, the host must be configured to talk to the instrument using EOI and no EOS.

Primary Address:	1-31
Secondary Address:	None
Timeout	2S
Terminate Read on EOS	NO
Set EOI with EOS on Writes	YES
EOS byte	N/A

Table 33: GPIB Host Setup Parameters

RS-232 Configuration

The RS-232 interface supports baud rates of 9600, 19,200, 38,400, 57,600 and 115200. The factory default is 9600.

The baud rate is changeable from the instrument's front panel by using the [System Functions Menu](#).

Other RS-232 communications parameters are fixed in the instrument. They are set as follows:

Parity: None, Bits: 8, Stop Bits: 1, Mode: Half Duplex

The RS-232 interface interface uses a "New Line", or Line Feed character as a line termination. In LabView™ or the C programming language, this character is `\n` or hexadecimal 0xA.

The controller will always return the `\n` character at the end of each line.

ⓘ Note: Some serial port software drivers allow the programmer to set a line termination character. This character is then appended to each string sent to the controller and stripped from returned strings. In this case, the `\n` (0xA) character should be selected.

Remote Programming Guide

General Overview

The IEEE-488.2 SCPI remote interface language is common to all Cryo-con products. Since the language supports both simple and advanced functions, it may initially seem complex. However, the use of English language keywords and a consistent tree-structured architecture make it easy to read and learn.

Language Architecture

The programming language used by all Cryo-con instruments is described as follows:

- The industry standard SCPI language defined by the IEEE-488.2 standard is used. Therefore, anyone with experience in test and measurement will find it familiar.
- All Cryo-con instruments use the same language and future instruments will continue in the same fashion. Therefore, your investment in system software will not be lost when a product is revised or replaced.
- Keywords used in commands are common English words, not cryptic acronyms. This makes command lines easy to read and understand, even for someone that is not familiar with the instrument.
- The SCPI is a 'tree structured' language where commands are divided into groups and associated commands into sub-groups. This architecture simplifies composing commands and improves readability.

Purpose

If the user's intent is to remotely program a Cryo-con instrument with fairly simple sequences, skip to the section titled [Commonly Used Commands](#). This is a simple cheat-sheet format list of the commands that are most frequently used.

For an advanced user familiar with the SCPI programming language, the section titled [Remote Command Descriptions](#) is a complete reference to all commands.

If you are unfamiliar with the SCPI language, but it is necessary to perform advanced programming tasks, SCPI is introduced in the next section.

For all users, the section titled "[Debugging Tips](#)" is often helpful and the "[Remote Command Tree](#)" is a single page listing that shows the syntax of each command.

An Introduction to the SCPI Language

SCPI is an acronym for **S**tandard **C**ommands for **P**rogrammable Instruments. Commonly pronounced 'skippy', it is an ASCII-based instrument command language defined by the IEEE-488.2 specification and is commonly used by test and measurement instruments.

SCPI commands are based on a hierarchical structure, also known as a tree system. In this system, associated commands are grouped together under a common node or root, thus forming subsystems. A portion the command tree for a Cryo-con instrument is shown here:

INPut	SYSTem
TEMPerature	BEEP
UNITs	ADRS
VARlance	LOCKout
SLOPe	
ALARm	
NAME	
LOOP	CONFig
SETPT	SAVE
RANGe	RESTore
RATE	

In the above, INPut and LOOP are root keywords whereas UNITs and RATE are second-level keywords. A *colon* (:) separates a command keyword from lower-level keyword.

Command Format

The format used to show commands is shown here:

```
INPut {A | B }:ALARm:HIGH <value>;NAME "name";
```

The command language is case-insensitive, but commands are shown here as a mixture of upper and lower case letters. The upper-case letters indicate the abbreviated spelling for the command. For shorter program lines, send the abbreviated form. For better program readability, send the long form.

For example, in the above statement, INP and INPUT are all acceptable.

Braces ({ }) enclose the parameter choices for a given command string. The braces are not sent as part of the command string.

A *vertical bar* (|) separates multiple parameter choices for a given command string.

Triangle brackets (< >) indicate that you must specify a numeric value for the enclosed parameter.

Double-quote (") marks must enclose string parameters.

Commands are terminated using a semicolon (;) character. The semicolon at the end of the line is assumed and is optional.

The { }, |, <> and " characters are for the illustration of the command syntax and not part of the command syntax.

Command Separators

A *colon* (:) is used to separate a command keyword from a lower-level keyword. It is necessary to insert a *blank space* to separate a parameter from a command keyword.

Compound Commands

A semicolon (;) is used as a separator character that separates commands within the same subsystem. For example, sending the following command string:

```
INPut A:UNITs K;TEMPer?;
```

has the same effect as sending the following two commands:

```
INPut A:UNITs K;  
INPut A:TEMPer?;
```

If multiple commands address different subsystems, the combination of a semicolon (;) and a colon (:) are used. The semi-colon terminates the previous command and the colon indicates that the next command is in a different subsystem. For example:

```
INPut A:TEMPer?;:LOOP 1:SETPt 123.45;
```

has the effect of sending the following two commands:

```
INPut A:TEMPer?;  
LOOP 1:SETPt 123.45;
```

Queries

You can query the current value of most parameters by adding a question mark (?) to the command. For example, the following command set the setpoint on control loop 1 to 123.45:

```
LOOP 1:SETPt 123.45;
```

You can change it into a query that reads the setpoint by using the following:

```
LOOP 1:SETPt?;
```

The instrument's response will be a numeric string such as: 123.45.

Compound queries are commonly used to save programming steps. For example, the query:

```
LOOP 1:SETPt?;PGAin?;IGAin?;DGAin?;
```

reports the loop 1 setpoint, P-gain, I-gain and D-gain. An example response is:

```
123.45;20.0;60;12.5;
```

Note that the response is also separated by semicolons.

The representation of the decimal symbol for floating point numbers must be a period, '.', instead of comma, ',' as is customary used in some European countries.

Command Terminators

Each command must be terminated with a *line-feed* (\n) character.

SCPI Common Commands

The IEEE-488.2 SCPI standard defines a set of common commands that perform basic functions like reset, self-test and status reporting. Note that they are called common commands because they must be common to all SCPI compliant instruments, not because they are commonly used.

Common commands always begin with an asterisk (*), are four to five characters in length and may include one or more parameters. Examples are:

```
*IDN?  
*CLS  
*OPC?
```

SCPI Parameter Types

The SCPI language defines several different data formats to be used in program messages and response messages.

Numeric Parameters: Commands that require numeric parameters will accept all commonly used decimal representations of numbers including optional signs, decimal points and scientific notation.

Enumeration Parameters: These are used to set values that have a limited number of choices. Query responses will always return an enumeration parameter in upper-case letters. Some examples of commands with enumeration parameters are:

```
INPut {A|B|C|D}:UNITs {K | C | F | S}  
LOOP {1 | 2}:TYPe {OFF | MAN | PID | TABLE | RAMPP}
```

String Parameters: String parameters can be up to 15 characters in length and contain any ASCII characters excluding the double-quote ("). String parameters must be enclosed in double-quotes ("). For example:

```
CONFig 4:NAME "Cold Plate"
```

Commonly Used Commands.

A complete summary of remote commands is given in the User's Manual chapter titled "Remote Command Summary". The manual also has complete descriptions of all remote commands. This section is intended to show a few of the more commonly used commands.

① **NOTE:** Remote commands are not case sensitive.

Function	Command	Comment
Instrument Identification		
Read the instrument identification string	*idn?	Returns the instrument identification string in IEEE-488.2 format. For example: "Cryo-con,24C,204683,1.01A" identifies the manufacturer followed by the model name, serial number and firmware revision code.
Input Channel Commands Parameter for the input is A, B, C or D corresponding to inputs A, B, C or D.		
Read the temperature on input channel B	input? b	Temperature is returned in the current display units. Format is a numeric string. For example: 123.4567
Set the temperature units on input channel A to Kelvin.	input a:units k	Choices are K- Kelvin, C- Celsius, F- Fahrenheit and S- native sensor units (Volts or Ohms).
Read the temperature units on channel B	input b:units?	Return is: K, C, F or S.
Control Loop Start/Stop commands		
Disengage all control loops.	stop	Both control loops are stopped.
Engage all control Loops.	control	Starts both control loops
Ask if control loops are on or off.	control?	Return is ON or OFF

Function	Command	Comment
LOOP Commands. Configure control loop outputs. Parameter is 1 or 2 corresponding to Loop 1 or Loop 2.		
Set the setpoint for control loop 1	loop 1:setpt 1234.5	Sets the loop 1 setpoint to 1234.5. Units are taken from the controlling input channel.
Read the setpoint for control loop 1	loop 1:setpt?	Reads the loop 1 setpoint as a numeric string.
Set the controlling source input for loop 1	loop 1:source a	Sets the Loop 1 controlling source to input channel A. Choices are any input channel.
Set the loop 2 P gain term for PID control.	loop 2:pgain 123.5	P gain is unit-less.
Set the loop 1 I gain term.	loop 1:igain 66.1	I gain has units of seconds.
Set the loop 2 D gain term.	loop 2:dgain 10.22	D gain has units of inverse-seconds.
Set the heater range for loop 1	loop 1:range hi	Choices are hi- high, mid- medium and low- low.
Read the loop 1 heater range	loop 1:range?	Reports HI, MID, LOW
Read the control mode for loop 1	loop 1:type?	Returns the control loop type. Choices are: OFF, MAN, PID, TABLE, RAMPT or RAMPP.
Set the control mode for loop 2	loop 2:type rampp	Choices are OFF, PID, MAN, TABLE and RAMPP
Set the output power level for manual control.	loop 1:pman 25	Sets the power output of loop 1 to 25% of full scale when the loop is in the manual output mode.
Read the current output power level	loop 2:htrread?	Reports the current output power as a percentage of full scale.

Debugging Tips

- To view the last command that the instrument received and the last response it generated, press the System key and then select the Network Configuration Menu. The last two lines of this menu show > and < characters. These two lines show the last command received by the instrument and the last response generated.
- Some commands require the instrument to write to non-volatile flash type memory, which can be time consuming. In order to avoid overrunning the instrument use compound commands that return a value, thus indicating that command processing is complete. For example:
 INPUT A:UNITS K;UNITS?
 will respond with the input units only after the command has completed.
 Another example:
 LOOP 1:SETPOINT 1234.5;:*OPC?
 Here, the operation complete command :*OPC? will return a '1' when command processing is complete.
- It is often easiest to test commands by using a simple terminal emulator that can be used to interact with the instrument via the LAN or serial ports. One example is The PuTTY program available at <http://www.putty.org/>. Configuring PuTTY for Ethernet communications with the M24C is shown here.
- Keywords in all SCPI commands may be shortened. The short form of a keyword is the first four characters of the word, except if the fourth is a vowel. If so, the truncated form is the first three characters of the word. Some examples are: inp for input, syst for system alar for alarm etc.

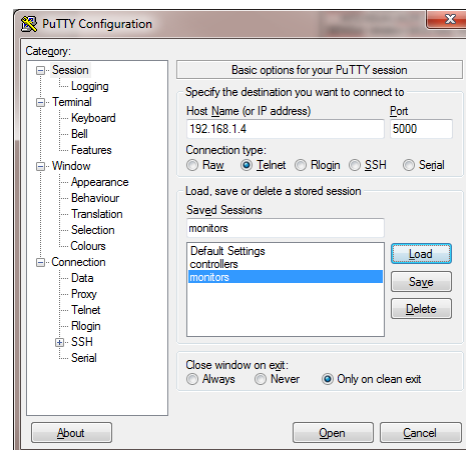

SCPI Status Registers

The Instrument Status Register

The Instrument Status Register (ISR) is queried using the SYSTEM:ISR? command.

The ISR is commonly used to generate a service request (GPIB) when various status conditions occur. In this case, the ISR is masked with the Instrument Status Enable (ISE) register.

The ISR is defined as follows:

ISR

Bit7	Bit6	Bit5	Bit4	Bit3	Bit2	Bit1	Bit0
Alarm			Htr			SFB	SFA

Where:

Bit7 – Alarm: Indicates that an alarm condition is asserted. Use the ALARM commands to query individual alarms.

Bit4 – Htr: Indicates a heater fault condition. Use the HEATER commands to query the heater.

Bit1 to Bit0 – SFx: Indicates that a sensor fault condition is asserted on an input channel. Use the INPUT commands to query the input channels.

The Instrument Status Enable Register

The Instrument Status Enable (ISE) Register is a mask register. It is logically ANDed with the contents of the ISR in order to set the Instrument Event (IE) bit in the Status Byte (STB) register. This can cause a service request (GPIB) to occur.

Bits in the ISE correspond to the bits in the ISR defined above.

The Standard Event Register

The Standard Event Register (ESR) is defined by the SCPI to identify various standard events and error conditions. It is queried using the Common Command *ESR?. This register is frequently used to generate an interrupt packet, or service request when various I/O errors occur.

Bits in the ESR are defined as follows:

ESR

Bit7	Bit6	Bit5	Bit4	Bit3	Bit2	Bit1	Bit0
OPC		QE	DE	EE	CE		PWR

Where:

Bit7 – OPC: Indicates Operation Complete.

Bit5 – QE: Indicates a Query Error. This bit is set when a syntax error has occurred on a remote query. It is often used for debugging.

Bit4 – DE: Indicates a Device Error.

Bit3 – EE: Indicates an Execution Error. This bit is set when a valid command was received, but could not be executed. An example is attempting to edit a factory supplied calibration table.

Bit2 – CE: Indicates a Command Error. This bit is set when a syntax error was detected in a remote command.

Bit0 – PWR: Indicates power is on.

The Standard Event Enable Register

The Standard Event Enable Register (ESE) is defined by the SCPI as a mask register for the ESR defined above. It is set and queried using the Common Command *ESE.

Bits in this register map to the bits of the ESR. The logical AND of the ESR and ESE registers sets the Standard Event register in the Status Byte (STB).

The Status Byte

The Status Byte (STB) is defined by the SCPI and is used to collect individual status bits from the ESE and the ISR as well as to identify that the instrument has a message for the host in it's output queue. It is queried using the Common Command *STB?. Bits are defined as follows:

STB

Bit7	Bit6	Bit5	Bit4	Bit3	Bit2	Bit1	Bit0
	RQS	SE	MAV	IE			

Where:

Bit6 – RQS: Request for Service.

Bit5 – SE: Standard Event. This bit is set as the logical 'AND' of the ESR and ESE registers.

Bit4 – MAV: Message Available

Bit3 – IE: Instrument Event. This bit is set as the logical 'AND' of the ISR and ISE registers.

The Status Byte Register

The Status Enable Register (SRE) is defined by the mask register for the STB. It is set and queried using the Common Commands *SRE.

The logical 'AND' of the SRE and STB registers is used to generate a service request on the GPIB interface.

Remote Command Tree

Control Loop Start /Stop commands

```
STOP  
CONTRol  
CONTRol?
```

SYSTEM commands

```
SYSTem:LOCKout {ON | OFF}  
SYSTem:NVSave  
SYSTem:REMLed {ON | OFF}  
SYSTem:BEEP <seconds>  
SYSTem:DISTc {0.5 | 1 | 2 | 4 | 8 | 16 | 32 | 64}  
SYSTem:ADRes <address>  
SYSTem:RESeed  
SYSTem:HOME  
SYSTem:NAME "name"  
SYSTem:HWRev?  
SYSTem:FWREV?  
SYSTem:LINEfreq {60 | 50}  
SYSTem:DRES {FULL | 1 | 2 | 3}  
SYSTem:PUControl {ON | OFF}  
SYSTem:BAUD {9600 | 19200 | 38400 | 57600 | 115200}  
SYSTem:DATE "mm/dd/yyyy"  
SYSTem:TIME "hh:mm:ss"
```

Configuration Commands

```
CONFig <ix>:NAME "name"  
CONFig <ix>:SAVe  
CONFig <ix>:RESTore
```

Input Commands

```

INPut? {A | B | C | D} or INPut {A | B | C | D}:TEMPerature?
INPut {A | B | C | D}:UNITs {K | C | F | S}
INPut {A | B | C | D}:NAME Instrument Name"
INPut {A | B | C | D}:SENPr?
INPut {A | B | C | D}:VBias {10MV | 3.0MV | 1.0MV | 300UV |
200UV | 100UV}
INPut {A | B | C | D}:BRANge {Auto | 1.0MA | 100UA |
10UA | 1.0UA}
INPut {A | B | C | D}:ACBias {On | Off}
INPut {A | B | C | D}:SENSorix <ix>
INPut {A | B | C | D}:BRUNlock?
INPut {A | B | C | D}:POWER?
INPut {A | B | C | D}:ALARm?
INPut {A | B | C | D}:ALARm:HIGHEst <setpt>
INPut {A | B | C | D}:ALARm:LOWEst <setpt>
INPut {A | B | C | D}:ALARm:DEAdband <setpt>
INPut {A | B | C | D}:ALARm:HIENa { YES | NO }
INPut {A | B | C | D}:ALARm:LOENa { YES | NO }
INPut {A | B | C | D}:Clear
INPut {A | B | C | D}:LTEna { YES | NO }
INPut {A | B | C | D}:AUDio { YES | NO }
INPut {A | B | C | D}:MINimum?
INPut {A | B | C | D}:MAXimum?
INPut {A | B | C | D}:VARiance?
INPut {A | B | C | D}:SLOpe?
INPut {A | B | C | D}:OFFSet?
INPut:TIME?
INPut:RESet
INPut {A | B | C | D}: TCSet

```

Loop Commands

```

LOOP {1 | 2 | 3 | 4}:SOURce {A | B | C | D}
LOOP {1 | 2 | 3 | 4}:SETPt <setpt>
LOOP {1 | 2 | 3 | 4}:ERRor?
LOOP {1 | 2 | 3 | 4}:TYPE
{ OFF | PID | MAN | TABLE | RAMPP | RAMPT}
LOOP {1 | 2 | 3 | 4}:TABelix <ix>
LOOP {1 | 2 | 3 | 4}:RANGe { HI | MID | LOW}
LOOP {1 | 2 | 3 | 4}:RAMP?
LOOP {1 | 2 | 3 | 4}:RATE <rate>
LOOP {1 | 2 | 3 | 4}:PGAin <gain>
LOOP {1 | 2 | 3 | 4}:IGAin <gain>
LOOP {1 | 2 | 3 | 4}:DGAin <gain>
LOOP {1 | 2 | 3 | 4}:PMAInal <pman>
LOOP {1 | 2 | 3 | 4}:OUTPwr?
LOOP {1 | 2 | 3 | 4}:HTRRead?
LOOP {1 | 2 | 3 | 4}:HTRHst?
LOOP {1}:LOAD {50 | 25}
LOOP {1 | 2 | 3 | 4}:MAXPwr <maxpwr>
LOOP {1 | 2 | 3 | 4}:MAXSet <maxset>

```

Autotune Commands

```

LOOP {1 | 2 | 3 | 4}:AUTotune:START
LOOP {1 | 2 | 3 | 4}:AUTotune:EXIT
LOOP {1 | 2 | 3 | 4}:AUTotune:SAVE
LOOP {1 | 2 | 3 | 4}:AUTotune:MODE {P | PI | PID}
LOOP {1 | 2 | 3 | 4}:AUTotune:DELTap <num>
LOOP {1 | 2 | 3 | 4}:AUTotune:TIMEout <num>
LOOP {1 | 2 | 3 | 4}:AUTotune:PGAin?
LOOP {1 | 2 | 3 | 4}:AUTotune:PGAin?
LOOP {1 | 2 | 3 | 4}:AUTotune:DGAin?
LOOP {1 | 2 | 3 | 4}:AUTotune:STATus?

```

OVERTEMP commands

```

OVERtemp:ENABLE {ON | OFF}
OVERtemp:SOURce {A | B | C | D}
OVERtemp:TEMPerature <temp>

```

Sensor Calibration Curve Commands

```

CALcur
SENSor <index>:NAME name string"
SENSor <index>:NENTry?
SENSor <index>:UNITs {VOLTS | OHMS | LOGOHM}
SENSor <index>:TYPE { DIODE | ACR | PTC100 | PTC1K |
    NTC10UA | ACR | TC70 | NONE }
SENSor <index>:MULTiplier <multiplier>

```

Relay Commands

```

RELay? {1 | 2}
RELay {1 | 2} :SOURce {A | B | C | D}
RELay {1 | 2} :MODE {auto | within | control | on | off}
RELay {1 | 2} :HIGHest <setpt>
RELay {1 | 2} :LOWEST <setpt>
RELay {1 | 2} :DEADband <deadband>
RELay {1 | 2} :HIENa { YES | NO }
RELay {1 | 2} :LOENa { YES | NO }
RELay {1 | 2} :TEMP?

```

PID Table Commands

```

PIDTable? <num>
PIDTable <num>:NAME Name String"
PIDTable <num>:NENTry?
PIDTable <num>
PIDTable <num>:TABLe

```

Network Commands

```
NETWork:IPAddress  
NETWork:PORT <port number>  
NETWork:MACAddress  
NETWork:NAME "Name"  
NETWork:DHCP {ON | OFF}
```

Mail Commands

```
MAIL {A | B | C | D} :ADDR "IPA"  
MAIL {A | B | C | D} :FROM "from e-mail address"  
MAIL {A | B | C | D} :DEST to e-mail address"  
MAIL {A | B | C | D} :PORT <port number>  
MAIL {A | B | C | D} :STATE {ON | OFF}
```

IEEE Common Commands

```
*CLS  
*ESE  
*ESR  
*OPC  
*IDN?  
*RST  
*SRE  
*STB
```

Data-logging Commands

```
DLOG:STATe {ON | OFF}  
DLOG:INterval <Seconds>  
DLOG:COUNT?  
DLOG?  
    DLOG:READ?  
DLOG:RESEt  
DLOG:CLEAR
```

Remote Command Descriptions

IEEE Common Commands

*CLS

The *CLS common command clears the status data structures, including the device error queue and the MAV (Message Available) bit.

*ESE

The *ESE command sets the Standard Event Status Enable (ESE) Register bits. The ESE Register contains a bit mask for the bits to be enabled in the Standard Event Status (SEV) Register. A one in the ESE register enables the corresponding bit in the SEV register. A zero disables the bit.

The *ESE? Query returns the current contents of the ESE register.

*ESR

The *ESR query returns the contents of the Standard Event (SEV) status register.

*OPC

The *OPC command causes the instrument to set the operation complete bit in the Standard Event (SEV) status register when all pending device operations have finished.

The *OPC Query places an ASCII '1' in the output queue when all pending device operations have completed.

*IDN?

The *IDN? Query causes the instrument to identify itself. The Model 24C will return the following string:

Cryo-con, 24C,<serial number>,<firmware revision>

Where: <serial number> is the unit's serial number and <firmware revision> is the revision level of the unit's firmware

*RST

Reset the controller. This results in a hardware reset in the Model 24C. The reset sequence takes about 15 seconds to complete. During that time, the instrument is not accessible over any remote interface.

The *RST command sets the Model 24C to its last power-up default setting.

*SRE

The *SRE command sets the Status Byte Enable (SRE) Register bits. The SRE Register contains a bit mask for the bits to be enabled in the Status Byte (STB) Register. A one in the SRE register will enable the corresponding bit in the STB register. A zero will disable the bit.

The *SRE? Query returns the current contents of the SRE register.

*STB?

The *STB query returns the contents of the Status Byte Register.

Control Loop Start / Stop Commands**STOP**

Disengage both control loops.

CONTRo1

The control command will cause the instrument to enter the control mode by activating enabled control loops. To disable an individual loop, set its control type to OFF.

① **Note:** To disengage temperature control, use the STOP command.

System Commands.

System commands are a group of commands associated with the overall status and configuration of the instrument rather than a specific internal subsystem.

SYSTEM: LOCKout {ON | OFF}

Sets or queries the remote lockout status indicator. Used to enable or lock-out the front panel keypad of the instrument, thereby allowing or preventing keypad entry during remote operation. When the keypad is locked, the Remote LED illuminates and most of the keys on the keypad will not function. However, the **Stop** key still functions.

To exit the keypad lock out from the front panel, push the **ESC(▼)** key. This will clear the Remote LED to indicate that the keypad is now unlocked.

SYSTEM: NVSave

Save NV RAM to Flash. This saves the entire instrument configuration to flash memory so that it will be restored on the next power-up. Generally only used in environments where AC power is not toggled from the front panel. This includes remote and rack-mount applications.

SYSTEM: REMLed {ON | OFF}

Sets or queries the remote LED status indicator on the instrument's front panel. Note that the Remote LED is automatically handled by the GPIB interface but must optionally be turned on and off when using the LAN or RS-232 interface.

SYSTEM: BEEP <seconds>

Asserts the audible alarm for a specified number of seconds. Command only, no query.

SYSTEM: DISTc {0.5 | 1 | 2 | 4 | 8 | 16 | 32 | 64}

Set or query the display filter time constant. The display filter is time-constant filter that is applied to all reported or displayed temperature data. Available time constants are 0.5, 1, 2, 4, 8, 16, 32 or 64 Seconds.

SYSTEM: ADRS <address>

Selects the address that the IEEE-488.2 (GPIB) remote interface will use. The address is a numeric value between 1 and 31 with a factory default of 12. The addresses assigned to instruments must be unique on each GPIB bus structure. This command has no effect on other interfaces.

SYSTem : RESeed

Re-seeds the input channel's averaging filter, allowing the reading to settle significantly faster. The display filter may have filter time-constants that are very long. The RESEED command inserts the current instantaneous temperature value into the filter history, thereby allowing it to settle rapidly.

ⓘ **Note:** The RESEED command is useful in systems where a computer is waiting for a reading to settle. Issuing the RESEED command will reduce the required settling time of the reading.

SYSTem : HOME

Causes the front panel display to go to the Operate Screen.

SYSTEM : NAME "name"

The controller contains a unit name string that may be set or queried using this command. This can be used to assign a descriptive name to the instrument.

SYSTem : HWRev?

Queries the instrument's hardware revision level.

SYSTem : FWREV?

Queries the instrument's firmware revision level.

SYSTem : LINEfreq {60 | 50}

Sets or queries the AC Power Line frequency setting which may be either 50 or 60 for 50Hz or 60Hz.

SYSTem:DRES {FULL | 1 | 2 | 3}

Sets or queries the controller's display resolution. Choices are:

- FULL: The display will show numbers with the maximum possible resolution.
- 1, 2 or 3: The display will show the specified number of digits to the right of the decimal point.

NOTE: This command only sets the number of digits displayed on the front panel display. It does NOT affect the internal accuracy of the instrument or the format of measurements reported on the remote interfaces.

The main use for this command is to eliminate the flicker in low order digits when the controller is used in a noisy environment.

SYSTem:PUControl {ON|OFF}

Sets or queries the controller's power up in control mode setting. Power-up in control mode causes the controller to automatically enter control mode 10 seconds after AC power is applied. Exercise caution when using this command as it can have unintended consequences.

SYSTem:BAUD {9600 | 19200 | 38400 | 57600 | 115200}

Sets or queries the RS 232 Baud rate.

SYSTem:DATE "mm/dd/yyyy"

Sets or queries the instrument's date. Date is in string format and is surrounded by double-quotes. Format is mm/dd/yyyy for month / day / year.

SYSTem:TIME "hh:mm:ss"

Sets or queries the instrument's time. Time is in string format and is surrounded by double-quotes. Format is hh:mm:ss for hour:mm:ss. Twenty-four hour format is used.

Configuration Commands**CONFig <ix>:NAME "name"**

Instrument setups can be named for user convenience. This command sets and queries the user configuration names. The parameter <ix> is the configuration number, which is 0 through 5. The second parameter, "name", is a string with a maximum length of 15 ASCII characters.

CONFig <ix>:SAVe

Saves the current instrument setup to a user setup. <ix> is the index number of the desired instrument setup. Values may be 0 through 5. Command only.

CONFig <ix>:REStore

Restores a previously stored user instrument setup. <ix> is the index number of the desired instrument setup. Values may be 0 through 5. Command only.

Input Commands

The INPUT group of commands are associated with the configuration and status of the four input channels.

Parameter references to the input channels may be:

- Numeric ranging in value from zero to two.
- Channel ID tags including CHA or CHB.
- Alphabetic including A or B.

INPut? {A|B|C|D} or INPut {A|B|C|D}:TEMPerature?

The INPUT query reports the current temperature reading on any of the input channels. Temperature is filtered by the display time constant filter and reported in display units. Query only.

INPut {A|B|C|D}:UNITs {K | C | F | S}

Sets or queries the display units of temperature used by the specified input channel. Units may be K for Kelvin, C for Celsius, F for Fahrenheit or S for primitive sensor units. In the case of sensor units, the instrument will determine if the actual units are Volts or Ohms based on the actual sensor type.

INPut {A|B|C|D}:NAME Name String"

Sets or queries the name string for the selected input channel. The name string can be up to 15 ASCII characters. The string is used to name the input channel in order to clarify it's use.

INPut {A|B|C|D}:SENPr?

The INPUT:SENPR query reports the reading on a selected input channel. For diode sensors, the reading is in Volts while resistor sensors are reported in Ohms. The reading is not filtered by the display time-constant filter. Query only.

INPut {A|B|C|D}:VBias {10MV | 3.0MV | 1.0MV | 300UV | 200UV | 100UV}

Sets or queries the constant-voltage mode voltage used on the specified input channel. This value only applies to sensors that use constant-voltage excitation. They are indicated by a sensor type of ACR. If this query is used with a sensor type other than ACR, it will always return N/A for not applicable.

INPut {A|B}:ACExcite {On|Off} Default: On

Applies to PTC100 and PTC1K sensors only. When AC excitation is selected a square-wave is used for sensor excitation. This is the default and gives best accuracy. In some systems, the AC excitation waveform can be picked up by sensitive equipment. In this case, AC excitation should be turned off.

INPut {A | B | C | D} Default: Auto

BRANge {Auto | 1.0MA | 100UA | 10UA | 1.0UA}

Sets or queries the resistance bridge range. This is a range-hold function. Normally, this is set to auto so that the instrument will autorange excitation. For special applications, the resistance bridge may be set to a specific excitation range.

INPut {A | B | C | D}: SENSor <ix>

Sets or queries the sensor index number. <ix>, is taken from Appendix A

INPut {A | B | C | D}: SENSPwr?

Queries the sensor power dissipation in Watts. Response is in scientific notation.

INPut {A | B | C | D}: BRUNlock?

Queries the bridge unlock indicator. Returns a space character if the bridge is locked or an asterisk (*) character if the bridge is unlocked.

If the bridge is unlocked, it is still searching for a balance point. The sensor reading will be correct, but the excitation current and power dissipation will be incorrect.

INPut {A | B | C | D}: ALARm?

Queries the alarm status of the specified input channel. Status is a two character string where:

--	indicates that no alarms are asserted
SF	indicates a Sensor Fault condition.
HI	indicates a high temperature alarm
LO	indicates a low temperature alarm.

The user selectable display time constant filter is applied to input channel temperature data before alarm conditions are tested.

INPut {A | B | C | D}: ALARm:HIGHest <setpt>

Sets or queries the temperature setting of the high temperature alarm for the specified input channel. When this temperature is exceeded an enabled high temperature alarm condition is asserted.

INPut {A | B | C | D}: ALARm:LOWest <setpt>

Sets or queries the temperature setting of the low temperature alarm for the specified input channel. When the input channel temperature is below this, an enabled low temperature alarm condition is asserted.

Temperature is assumed to be in the display units of the selected input channel.

INPut {A | B | C | D}: ALARm:DEAdband <setpt>

Sets or queries the dead-band setting. Dead-band is assumed to be in the display units of the selected input channel.

INPut {A | B | C | D}: ALARm:HIENa { YES | NO}

Sets or queries the high temperature alarm enable for the specified input channel. An alarm must be enabled before it can be asserted.

- INPut {A | B | C | D}:ALARm:LOENa {YES | NO }**
Sets or queries the low temperature alarm enable for the specified input channel. An alarm must be enabled before it can be asserted.
- INPut {A | B | C | D}:ALARm:LTENa {YES | NO }**
Sets or queries the latched alarm enable mode. When an alarm is latched, it can be cleared by using the CLear command.
- INPut {A | B | C | D}:ALARm:CLEAr**
Clears any latched alarm on the selected input channel.
- INPut {A | B | C | D}:ALARm:AUDio {YES | NO }**
Sets or queries the audio alarm enable. When enabled, an audio alarm will sound whenever an alarm condition is asserted.
- INPut {A | B | C | D}:MINimum?**
Queries the minimum temperature that has occurred on an input channel since the statistics were reset.
- INPut {A | B | C | D}:MAXimum?**
Queries the maximum temperature that has occurred on an input channel since the statistics were reset.
- INPut {A | B | C | D}:VARiance?**
Queries the temperature variance that has occurred on an input channel since the statistics were reset. Variance is calculated as the Standard Deviation squared.
- INPut {A | B | C | D}:SLOpe?**
Queries the input channel statistics. SLOPE is the slope of the best fit straight line passing through all temperature samples that have been collected since the statistics were reset. SLOPE is in units of the input channel display per Minute.
- INPut {A | B | C | D}:OFFSet?**
Queries the input channel statistics. OFFSET is the offset of the best fit straight line passing through all temperature samples that have been collected since the statistics were reset. OFFSET is in units of the input channel display.
- INPut {A | B | C | D}:STATs:TIME?**
Queries the time duration over which input channel statistics have been accumulated. Query only.
- INPut {A | B | C | D}:STATs:RESet**
Resets the accumulation of input channel statistical data. Command only affects the selected input channel.
- INPut {A | B | C | D}:TCOFFset <offset>**
Sets or queries the offset value for thermocouple inputs. <offset> is the decimal value of offset and is in units of Kelvin. Refer to the section on [Using Thermocouple Sensors](#) for more information.

LOOP commands

Loop commands are used to configure and monitor the controller's temperature control loops.

LOOP {1 | 2 | 3 | 4}:SOURCE {A | B | C | D}

Sets and queries the selected control loop's controlling input channel, which may be any one of the four input channels.

LOOP {1 | 2 | 3 | 4}:SETPt <setpt>

Sets and queries the selected control loop's setpoint. This is a numeric value that has units determined by the display units of the controlling input channel. Values above the one set in the maximum setpoint, or below zero are rejected.

LOOP {1 | 2 | 3 | 4}:ERROR?

Queries the selected control loop's error status. Return is one of the following:

--Htr OK-- No error
 -Overtemp- Disengaged, Internal circuits are over temperature.
 OTDisconn Disengaged by Over temperature disconnect.
 Htr-Low-R Disengaged, Load resistance too low.
 Fan Fault Loop 1 disengaged, Fan speed low.

**LOOP {1 | 2 | 3 | 4}:TYPE
{ OFF | PID | MAN | TABLE | RAMPP }**

Sets and queries the selected control loop's control type. Allowed values are:

Off - loop disabled
PID - loop control type is PID
Man - loop is manually controlled
Table - loop is controlled by PID Table lookup.
RampP - loop is controlled by PID, but is in ramp mode.
RampT - loop is controlled by PID Table lookup, but is in ramp mode.

LOOP {1 | 2 | 3 | 4}:TABLEix <ix>

Sets and queries the number of the PID table used when controlling in Table mode. Six PID tables are available to store PID parameters vs. setpoint and heater range. <ix> is the loop's control PID table index.

Table index is in the range of 1 through 6.

LOOP 1:RANGe { HI | MID | LOW }

LOOP 2:RANGe { HI | LOW }

LOOP {3 | 4}:RANGe { 5V | 10V }

Sets or queries the control loop's output range.

Range determines the maximum output power available and is different for a 50 Ω load resistance than for a 25 Ω load.

Values of heater range for Loop 1 are: Hi, Mid and Low. These correspond to the output power levels shown here.

The values for loop #2 are Hi and Low, corresponding to 25W or 2.5W into a 50 Ω load.

Non-powered loops #3 and #4 have ranges of 5V or 10V corresponding to a 5- or 10-Volt full-scale output.

Range	50 Ω Load	25 Ω Load
Hi	50W	25W
Mid	5W	2.5W
Low	0.5W	0.25W

Table 34: Loop #1 Ranges

Range	50 Ω Load
Hi	25W
Low	2.5W

Table 35: Loop #2 Ranges

LOOP {1 | 2 | 3 | 4}: RAMP?

Queries the unit to determine if a temperature ramp is in progress on the specified control loop. Note that temperature ramps on the Loop 1 and Loop 2 channels are independent of each other. Query response is ON or OFF.

LOOP {1 | 2 | 3 | 4}: RATE <rate>

Sets and queries the ramp rate used by the selected control loop when performing a temperature ramp. <rate> is the ramp rate in Units / Minute. This may be a value between 0 and 100. Rate is in display units per Minute.

LOOP {1 | 2 | 3 | 4}: PGAin <gain>

Sets or queries the selected control loop's proportional gain term. This is the P term in PID and is a unit-less numeric field with values between 0 (off) and 1000.

LOOP {1 | 2 | 3 | 4}: IGAin <gain>

Sets and queries the integrator gain term used by the selected control loop. This is a numeric field with units of seconds. Allowed values are 0 (off) through 1000 seconds.

LOOP {1 | 2 | 3 | 4}: DGAin <gain>

Sets and queries the differentiator gain term used by the selected control loop. This is a numeric field with units of inverse seconds. Allowed values are 0 (off) through 1000/Seconds.

Note: Use of the D gain term can add significant noise. It should never be set to a value greater than 1/4 of the integrator gain.

LOOP {1 | 2 | 3 | 4}: PMANua1 <pman>

Sets and queries the output power level used by the selected control loop when it is in the manual control mode. <value> is the desired selected control loop output power. This is a numeric field in units of percent of full scale. Actual output power will depend on the loop range setting.

LOOP {1 | 2 | 3 | 4}: OUTPwr?

Queries the output power of the selected control loop. This is a numeric field that is a percent of full scale.

LOOP {1 | 2 | 3 | 4}: HTRRead?

Queries the actual output power of either control loop. The output current of the heaters is continuously monitored by an independent read-back circuit. The read-back power reported by this command is a percent of full scale. The absolute value of full scale is determined by the selected heater range.

Note that the read-back value is a percent of full-scale power. To compute the output current, first compute the square-root of the read-back value.

LOOP {1}: LOAD {50 | 25}

Sets or queries the load resistance setting of the primary heater (Loop 1). Selections are:

50 for a 50 Ω load and a 50W maximum output power.

25 for a 25 Ω load and a 25W maximum output power.

Note: Loop #2 supports loads to 10 Ω load, so this command is ignored.

LOOP {1 | 2 | 3 | 4}: MAXPwr <maxpwr>

Sets or queries the maximum output power setting of the selected control loop. <MaxPwr> is the desired maximum output power limit expressed as a percentage of full scale.

LOOP {1 | 2 | 3 | 4}: MAXSet <maxset>

Sets or queries the maximum allowed set point for the selected control loop. <MaxSet> is the desired maximum set point. Setpoint values are in units of the controlling input channel.

LOOP {1 | 2 | 3 | 4}: VSENse?

Queries the control loop output voltage. If the instrument is not controlling temperature, return is 0.00V.

LOOP {1 | 2 | 3 | 4}: ISENse?

Queries the control loop output current. If the instrument is not controlling temperature, return is 0.00A.

LOOP {1 | 2 | 3 | 4}: LSENse?

Queries the control sensed load resistance. If the instrument is not controlling temperature, return is -1.00.

LOOP {1 | 2 | 3 | 4}: HTRHst?

Queries the temperature of the control loop's heat sink. Valid for loops #1 and #2 only. Returns temperature in $^{\circ}\text{C}$.

Control Loop Autotune Commands

The Model 24C's control loop autotune functions can be configured and run entirely from the remote interface. The general sequence is:

1. Configure the autotune parameters.
2. Initiate the autotune sequence.
3. Read the autotune state and wait for the sequence to complete.
4. Execute the autotune save command to transfer the generated tuning parameters to the controller's PID values and continue with PID control.

LOOP {1 | 2 | 3 | 4}: AUTotune : START

Command to initiate the autotune sequence on the selected control loop.

LOOP {1 | 2 | 3 | 4}: AUTotune : EXIT

Command to abort the autotune sequence.

LOOP {1 | 2 | 3 | 4}: AUTotune : SAVE

Command to save the autotune generated PID values to the selected control loop and continue with PID regulation.

LOOP {1 | 2 | 3 | 4}: AUTotune : MODE {P | PI | PID}

Set or query the autotune mode. Choices are P to generate P only tuning values, PI for PI values and PID for all values. Recommended value is PID.

LOOP {1 | 2 | 3 | 4}: AUTotune : DELTap <num>

Set or query the maximum allowed change in output power that the controller is allowed to generate. Parameter is numeric and is in percent of full-scale output power. A common value is 5 for 5%.

LOOP {1 | 2 | 3 | 4}: AUTotune : TIMEout <num>

Set or query the autotune timeout. Parameter is numeric and is in units of Seconds.

LOOP {1 | 2 | 3 | 4}: AUTotune : PGAin?

Query the autotune generated proportional or P-gain parameter. This query will return a value of -1 until the autotune status is Complete".

LOOP {1 | 2 | 3 | 4}: AUTotune : PGAin?

Query the autotune generated integrator or I-gain parameter. This query will return a value of -1 until the autotune status is Complete".

LOOP {1 | 2 | 3 | 4}: AUTotune : DGAin?

Query the autotune generated derivative or D-gain parameter. This query will return a value of -1 until the autotune status is Complete".

LOOP {1 | 2 | 3 | 4}: AUTotune : STATus?

Queries the status of the autotune process. Return values are:

IDLE	- Autotune has not started.
RUNNING	-Autotune is running.
COMPLETE	-Autotune successfully completed.
FAILED	-Unable to generate PID values.
ABORT	-Aborted by operator intervention.

OVERTEMP commands

These commands are associated with the heater's Over Temperature Disconnect (OTD) feature. This is used to disconnect the heater if a specified temperature is exceeded on any selected input channel.

OVERtemp:ENABLE {ON | OFF}

Sets and queries the Over Temperature Disconnect enable. The OTD does not function if disabled.

OVERtemp:SOURce {A | B | C | D}

Sets and queries the input channel that is used as the source for the Over Temperature Disconnect feature.

OVERtemp:TEMPerature <temp>

Sets and queries the temperature used by the over temperature disconnect feature. Note that this temperature has the same units of the source input channel.

Relay Commands

The relay subsystem includes the two auxiliary relays in the Model 24C. Using the RELAY commands, these relays are independently configured to assert or clear based on the status of any of the four sensor input channels.

Relay outputs are dry-contact and are available on the rear panel of the instrument.

The user selectable display time constant filter is applied to input channel temperature data before relay conditions are tested. The user selectable relay deadband is also applied.

RELay? {1 | 2}

Relay Status Query. The two auxiliary relays available in the Model 24C are addressed as 0 and 1. The RELAYS command can be used to query the status of each relay where:

--	Relay is in Auto mode and is clear.
HI	Relay is asserted by a high temperature condition.
LO	Relay is asserted by a low temperature condition.
ON	Relay is in manual mode and is asserted.
OFF	Relay is in manual mode and is clear.

RELay {1 | 2}:SOURce {A | B | C | D}

Relay Input Source. Sets or queries the source input channel for a specified relay.

RELay {1 | 2}:HIGHest <setpt>

Relay High setpoint. Sets or queries the temperature setting of the high temperature setpoint for the specified relay. Parameter <setpt> is floating-point numeric and is in units of the controlling input channel.

RELay {1 | 2}:MODE {AUTO | WITHIN | ON | OFF}

Set or query the relay mode. Modes are:

Auto	Relay is controlled by enabled high and low setpoints.
Within	Operation is inverse of Auto mode. Used for fail-safe operation.
ON	Relay is in manual mode and is asserted.
OFF	Relay is in manual mode and is clear.
Control	Relay is asserted whenever the controller is in Control mode.

RELay {1 | 2}:LOWest <setpt>

Relay Low setpoint. Sets or queries the temperature setting of the low temperature setpoint for a specified relay. Parameter <setpt> is floating-point numeric and is in units of the controlling input channel.

RELay {1 | 2}:HIENa {YES | NO }

Relay High Enable. Sets or queries the high temperature enable for the specified relay.

RELay {1 | 2}:LOENa {YES | NO }

Relay Low Enable. Sets or queries the low temperature enable for the specified relay.

RElAy {1 | 2}: DEAdband <dead-band>

Sets or queries the dead-band parameter. This controls the amount of hysteresis that is applied before a relay is asserted or cleared. Parameter <dead-band> is floating-point numeric and is in units of the controlling input channel.

Sensor Calibration Curve Commands

The CALCUR commands are used to transfer sensor calibration curves between the instrument and the host controller.

Curves are referenced by an index number. In the Model 24C, there are eight user curves numbered 1 through 8.

The CALCUR data block consists of many lines of ASCII text. The format is the same as the file format for user calibration curves, which is detailed in the section [User Calibration Curve File Format](#)

CALCUR <index>

Sets or queries sensor calibration curve data.

Uses a fragmented message protocol to send many lines of ASCII text to the instrument.

Note: It is much easier to use Cryo-con's Utility Software to send and receive sensor calibration curves.

ⓘ **NOTE:** The instrument takes about five seconds to process and store a calibration curve. Please insert this time delay between transferring sequential curves.

Sensor commands

Sensor commands are used to set and query information about the sensors installed in the controller. Both factory and user installed sensors can be queried, but only user sensors may be edited.

ⓘ **NOTE:** Factory installed sensors are indexed from 0 to 61. User installed sensors have index values from 61 to 68 corresponding to user curves 1 through 8. For additional information, refer to [Appendix A](#).

SENSorix <index>:name "Name String"

Sets and queries the name string of the user-installed sensor at index <index>. The name string can be up to 15 ASCII characters.

SENSorix <index>:NENTry?

Queries the number of entries in the user-installed sensor at index <index>. Response is a decimal integer ranging from zero to 200.

SENSorix <index>:UNITs {VOLT| LOGOHM | OHMS}

Sets or queries the units of a user installed calibration curve at <index>. For information on the curve units, refer to the [User Calibration Curve File Format](#) section.

SENSorix <index>:**TYPE {DIODE | ACR | PTC100 | PTC1K | TC70}**

Sets or queries the type of sensor at <index>. For more information on sensor types, please refer to the [Input Configurations](#) section. Index is 0 through 7.

SENSorix <index>:MULTIply <multiplier>

Sets or queries the multiplier field of a user installed calibration curve at <index>. For information on the multiplier, refer to the [User Calibration Curve File Format](#) section.

PIDTABLE commands

The PIDTABLE commands are used to transfer PID tables between the Model 24C and the host computer. Use of the Cryo-con Utility software to transfer PID tables is recommended since the process is relatively complex.

PIDTable? <index>

Queries the name string of a PID table at a specified index.

PIDTable <index>:NAME "Name"

Sets or queries the name string of the PID Table at a specified index. The name string is used to associate a convenient name with a PID table. It may include up to 15 ASCII characters.

PIDTable <index>:NENTry?

Queries the number of entries in a PID Table. This number is generated from the table itself and cannot be changed using this command.

PIDTable <index>:TABLE

Uploads or downloads a complete PID table. Transfer will end on a line containing a single semi-colon.

Network Commands

The following commands are used to configure the Model 24C's Ethernet interface.

NETWork: IPADdress "IPA"

Sets or queries the controller's IP address. The address is expressed as an ASCII string, so the input parameter must be enclosed in quotes. For example, the default IP address parameter is 192.168.1.5".

NETWork: PORT <port number>

Sets or queries the controller's TCP port number. Default is 5000.

NETWork: NAME "Name"

Sets or queries the controller's network name. This name is expressed as an ASCII string, so the input parameter must be enclosed in quotes. Maximum of 15 characters.

NETWork: DHCP {ON | OFF}

Sets or queries the controller's DHCP status.

NETWork: MACADdress?

Queries the controller's MAC address. The address is returned as an ASCII string. Cryo-con MAC addresses range from 00:50:C2:6F:40:00 to 00:50:C2:6F:4f:ff. They cannot be changed by the user.

Mail Commands

The Model 24C can send e-mail over the Ethernet port when an alarm condition is asserted on an enabled input channel. The following remote commands are used to configure e-mail. However, it is much easier to configure e-mail using the controller's embedded web server.

MAIL {A | B | C | D}: ADDR "IPA"

Set or query the e-mail server IP address. Parameter format is an ASCII string and must be enclosed in quotation marks. For example: 192.168.0.1".

MAIL {A | B | C | D}: FROM "from e-mail address"

Set or query the 'from' e-mail address. Parameter is an ASCII String. For example: Model24C@mynetwork.com".

MAIL {A | B | C | D}: DEST "to e-mail address"

Set or query the 'to' e-mail address. Parameter is an ASCII String. For example: Model24@mynetwork.com".

MAIL {A | B | C | D}: PORT <port number>

Set or query the e-mail port. Parameter is integer and default is 25.

MAIL {A | B | C | D}: STATE {ON | OFF}

Set or query the input channel e-mail send enables. If a channel is enabled, e-mail will be sent when an alarm condition is asserted on the selected input channel.

Data Logging Commands**DLOG:STATe {ON | OFF}**

Turns the data logging function ON or OFF. Equivalent to Start / STOP.

DLOG:INTerval <Seconds>

Sets the data logging time interval in seconds.

DLOG:COUNT?

Queries the number of entries in the log buffer.

DLOG?**DLOG:READ?**

Reads the entire contents of the log buffer. Each record is sent on a single line. Format is:

<#>, MM/DD/YYYY, HR,MN,SC, ChA, ChB, ChC,ChD

where:

<#> is the record number.

MM/DD/YYYY is the date in Month, Day, Year format.

HR,MN,SC is the time in Hour, Minute, Second format.

Lines end with a <CR><LF> sequence. End of transmission is indicated by a line that only contains a semi-colon.

DLOG:RESEt

Sets the logging record number to zero.

DLOG:CLEAr

Clears the data logging buffer.

EU Declaration of Conformity

Product Category: Measurement, Control and Laboratory
Product Type: Temperature Measuring and Control System
Model Numbers: Model 24C
Manufacturer's Name: Cryogenic Control Systems, Inc.
Manufacturer's Address:
P. O. Box 7012
Rancho Santa Fe, CA 92067
Tel: (858) 756-3900, Fax: (858) 759-3515

The before mentioned products comply with the following EU directives:

2004/108/EC, EMC, Electromagnetic compatibility.

2006/95/EC, LVD, Electrical equipment designed for use within certain voltage limits.

2011/65/EU, RoHS, Restriction of the use of certain hazardous substances in electrical and electronic equipment.

The compliance of the above mentioned product with the Directives and with the following essential requirements is hereby confirmed:

Emissions

EN 55011, 1998

Immunity

EN 50082-1, 1997

Safety

EN 61010-1:2010
IEC 61010-1:2010

RoHS

50581:2012

As the manufacturer we declare under our sole responsibility that the above mentioned products comply with the above named directives.

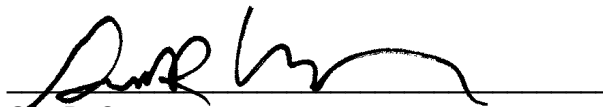

Guy D. Covert
President, Cryogenic Control Systems, Inc.
May 1, 2017

Appendix A: Installed Sensor Curves

Factory Installed Curves

The following is a list of factory-installed sensors and the corresponding sensor index.

Sensor IX	Name	Description
0	None	No Sensor. Used to turn the selected input channel off.
1	Cryo-con S900	Cryo-con S900 series Silicon diode. Range: 1.4 to 500K. 10 μ A constant current excitation.
2	LS DT-670	Lakeshore DT-670 series Silicon diode, Curve 11. Range: 1.4 to 500K. 10 μ A constant current excitation.
3	LS DT-470	Lakeshore DT-470 series Silicon diode, Curve 10. Range: 1.4 to 500K. 10 μ A constant current excitation.
4	Cryo-con S950	Cryo-con S950 series Silicon diode. Range: 1.4 to 400K. 10 μ A constant current excitation.
5	SI 410 Diode	Scientific Instruments, Inc. 410 diode Curve. Range: 1.5 to 450K. 10 μ A excitation.
20	Pt100 385	DIN43760 standard 100 Ω Platinum RTD. Range: 23 to 873K, 1mA excitation.
21	Pt1K 385	1000 Ω at 0 $^{\circ}$ C Platinum RTD using DIN43760 standard calibration curve. Range: 23 to 1023K, 100 μ A excitation.
22	Pt10K 385	10K Ω at 0 $^{\circ}$ C Platinum RTD. Temperature coefficient 0.00385, Range: 23 to 873K, 10 μ A excitation.
32	RO-600C	Scientific Instruments Inc. RO-600 Ruthenium-Oxide sensor with constant-voltage AC excitation. Temperature range is: 1.0K to 40K.
45	TC Type K	Thermocouple, Type K. Range: 3.2 to 1643K
46	TC Type E	Thermocouple, Type E. Range: 3.2 to 1273K
47	TC Type T	Thermocouple, Type T. Range: 3.2 to 673K
48	TC AuFe .07%	Chromel-AuFe 7% thermocouple. Range: 3 to 610K
59	Internal	Internal reference temperature.

The SENSORIX remote commands are used to query and edit sensors installed in the controller. For example, the command:

INPUT B SENSORIX 32 would set input B to use the ACR sensor.
 INPUT A: SENSORIX 1 would set input A to use the S900 diode.
 INPUT A: SENSORIX 0 would turn input A off by setting the sensor to 'none'.
 SENSORIX 1:NAME? Returns the name string at index 1.

Factory installed sensors may not be edited by using these commands.

User Installed Sensor Curves

The user may install up to four custom sensors. This table shows the sensor index and default name of the user curves:

User Curve	Sensor IX	Default Name
0	61	User Sensor 1
1	62	User Sensor 2
2	63	User Sensor 3
3	64	User Sensor 4
4	65	User Sensor 5
5	66	User Sensor 6
6	67	User Sensor 7
7	68	User Sensor 8

Using the above table, the SENSORIX commands can be used to address the user curves. For example:

INPUT B SENSOrIx 62 assigns input B to user sensor #2.
 SENSOrIx 64:NAME? Returns the name string of user sensor 4
 SENSOrIx 63:TYPE ACR sets the type of user sensor #3 to ACR.

ⓘ NOTE: Factory installed sensors are indexed from 0 to 60. User installed sensors have index values from 61 to 68 corresponding to user curves 1 through 8.

Sensor Curves on CD

The following sensors are available on the CD supplied:

File	Description
Cryocon S700	Cryo-con S700 series Silicon diode. Range: 1.4 to 500K. 10 μ A constant current excitation.
CryocalD3.crv	Cryocal D3 Silicon diode. Range: 1.5 to 300K
SI410.crv	Scientific Instruments, Inc. SI-410 Silicon diode. Range: 1.5 to 450K
Curve10.crv	Lakeshore Curve 10 Silicon diode curve for DT-470 series diodes. Range: 1.4 to 495K.
Curve11.crv	Lakeshore Curve 10 Silicon diode curve for DT-670 series diodes. Range: 1.4 to 500K.
PT100385.crv	Cryocon CP-100, DIN43760 or IEC751 standard Platinum RTD, 100 Ω at 0 $^{\circ}$ C. Range: 23 to 1020K
PT1K385.crv	DIN43760 or IEC751 standard Platinum RTD, 1000 Ω at 0 $^{\circ}$ C. Range: 23 to 1020K
PT1003902.crv	Platinum RTD, 100 Ω at 0 $^{\circ}$ C Temperature coefficient 0.003902 Ω /C. Range: 73K to 833K.
PT1K375.crv	Platinum RTD, 1000 Ω at 0 $^{\circ}$ C Temperature coefficient 0.00375 Ω /C. Range: 73K to 833K.
aufe07cr.crv	Chromel-AuFe 7% thermocouple. Range: 3 to 610K
TCTypeE.crv	Thermocouple, Type E. Range: 3.2 to 1273K
TCTypeK.crv	Thermocouple, Type K. Range: 3.2 to 1643K
TCTypeT.crv	Thermocouple, Type T. Range: 3.2 to 673K
CX1030E1.crv	Cernox™ CX1030 example curve. Range: 4 to 325K

Sensor Calibration Curve File Format

① Note: One simple way to generate a sensor calibration curve is to open a similar sensor file with a text editor and paste in your own data. The example files in the above table are for that purpose. They are located crv_files sub-directory of the Cryo-con utility software package. For NTC thermistors, try the AB270.crv file, for Diodes the S900.crv file and PTC RTDs use the PT100385.crv

Sensor calibration curves may be sent to any Cryo-con instrument using a properly formatted text file. This file has the extension .crv. It consists of a header block, lines of curve data and is terminated by a single semicolon (;) character.

The header consists of four lines as follows:

```
Sensor Name: Sensor name string
Sensor Type: Enumeration
Multiplier: Signed numeric
Units: Units of calibration curve: {OHMS | VOLTS | LOGOHM}
```

The Sensor Name string can be up to 15 characters and is used to identify the individual sensor curve. When downloaded to a Cryo-con instrument, this name appears in the sensor selection menu of the embedded web server and will appear on all sensor selection fields on the front panel.

The Sensor Type Enumeration identifies the required input configuration of the input channel. For the Model 24C, selections are: DIODE, PTC100, PTC1K, TC70, NONE and ACR. These configurations are described in the section titled [Supported Sensor Configurations](#).

Note that, when type ACR is selected, the default voltage bias may be entered next to it. If no voltage is selected, the default of 10mV will be used.

The Multiplier field is a signed, decimal number that identifies the sensor's temperature coefficient and curve multiplier. Generally, for Negative-Temperature-Coefficient (NTC) sensors, the value of the multiplier is -1.0 and for a Positive-Temperature-Coefficient (PTC) sensor, the value is 1.0.

As an advanced function, the multiplier field can be used as a multiplier for the entire calibration curve. For example, a 10K Ω Platinum RTD can use a calibration curve for a 100 Ω Platinum RTD by using a multiplier of 100.0.

The fourth line of the header is the sensor units field. This may be Volts, Ohms or Logohm. Generally, diode type sensor curves will be in units of Volts and most resistance sensors will be in units of Ohms. However, many resistance sensors used at low temperature have highly nonlinear curves. In this case, the use of Logohm units give a more linear curve and provide better interpolation accuracy. Logohm is the base-10 logarithm of Ohms.

Examples of sensor calibration curves that are in units of Ohms include Platinum RTDs and Rhodium-Iron RTDs. Examples of sensors that best use Logohm include Cernox™, Ruthenium-Oxide and Carbon-Ceramic.

After the header block, there are two to 200 lines of sensor calibration data points. Each point of a curve contains a sensor reading and the corresponding temperature. Sensor readings are in units specified by the units line in the curve header. Temperature is always in Kelvin.

The format of an entry is:

<sensor reading> <Temperature>

Where <sensor reading> is a floating-point sensor reading and <Temperature> is a floating-point temperature in Kelvin. Numbers are separated by one or more white spaces.

Floating point numbers may be entered with many significant digits. They will be converted to 32 bit floating point which supports about six significant digits.

The last entry of a table is indicated by a semicolon (;) character with no characters on the line.

<p>ⓘ NOTE: All curves must have a minimum of two entries and a maximum of 200 entries.</p>

Entries may be sent to the instrument in any order. The instrument will sort the curve in ascending order of sensor reading before it is copied to Flash RAM. Entries containing invalid numeric fields are deleted before the curve is stored.

The following is an example of a calibration curve transmitted to the instrument via the LAN interface:

```
Good Diode
Diode
-1.0
volts
0.34295 300.1205
0.32042 273.1512
0.35832 315.0000
1.20000 3.150231
1.05150 8.162345
0.53234 460.1436
;
```

In summary,

1. Lines must always be terminated by a line-feed character (`\n`). Carriage-return characters (`\r`) are ignored.
1. The first line is a name string that can be up to 15 characters. Longer strings are truncated by the instrument.
The second line identifies the instrument's input configuration and must be one of the allowed selections described in the [Supported Sensor Configurations](#) section.
2. The third line is the multiplier field and is 1.0 for PTC sensors and -1.0 for NTC sensors or diodes.
3. The fourth line of the header is the sensor units and must be Volts, Ohms or Logohm.
4. Curve entries must be the sensor reading followed by the temperature in units of Kelvin. Values are separated by one or more white space or tab characters.
5. The last line in the file has a single semicolon (`;`) character. All lines after this are rejected.
6. It is recommended that the curve back is read after downloading to ensure that the instrument parsed the file correctly. This is easily done by using the Cryo-con utility software's curve upload function under `Operations>Sensor Curve>upload`.

Appendix B: Updating Instrument Firmware

Updates require the use of the Cryo-con Firmware Update Utility software and a hex file containing the updated firmware. These are available on the Internet.

ⓘ Note: Updating firmware in any instrument is not entirely without risk. Please only perform the procedure when some down time is available.

The update will abort on the detection of a hardware malfunction. Also, the update may change instrument features that you are currently using in a different way. Factory defaults settings are restored that will erase any existing user calibration curves or PID tables.

Discussion

Cryo-con instruments have two blocks of flash type program memory. In the standard configuration, the Internal block contains a boot-loader program and the External block contains the actual instrument firmware.

During the normal power-up sequence, the boot-loader tests the external flash memory and then transfer execution to it in order to run the instrument's firmware. From there, the Cryo-con firmware update utility can be used to update instrument's firmware.

The firmware update sequence is as follows:

1. Connect the LAN port of the instrument to your PC, turn the instrument ON and then run the FWutility.exe.
2. Click the Connect button to connect the PC to the instrument using TCP/IP. If there is an error, a dialog box will appear. Correct the problem and re-try.
3. While connected, the instrument still functions normally. Click on the Set Flash Mode button to place the instrument in the firmware update mode. In this mode, the instrument executes the boot-loader from the Internal flash memory and is waiting to program the External memory with the new firmware.
4. Click Connect again and then click the Program / Verify button to start the update process.
5. When the update process is complete, the instrument will automatically reset itself and start running the updated firmware.

Updating unit firmware

Before starting, be sure to have the **FWutility.exe** file and a hex file that contains the desired firmware update.

On the instrument, check the current hardware and firmware revision by pressing the System key and scrolling down to the revision field. A typical display is:

FW Ver: 3.00D

meaning that the instrument has firmware revision 3.00 and hardware revision D.

The name of the hex file is used to identify the firmware update. For example:

M24C_301.hex

specifies that this is revision 3.01 for a Model 24C with hardware revision C.

ⓘ Note: The flash loader software does NOT check the hex file for compatibility with the target instrument. Please be sure that you are using the correct file.

Connecting a PC to the instrument

It is recommended that the instrument is connected directly to a PC using a LAN patch cable. Note, Model 24C hardware revisions previous to D required a crossover patch cable.

From the PC, open the network connections dialog, select the network adapter that you are using with the Cryo-con instrument and select "Internet Protocol (TCP/IP). In the TCP/IP dialog box, select 'Use the following IP' addresses and enter following:

IP address: 192.168.1.10

Subnet mask: 255.255.255.0

Other fields are not used. Click OK. This should allow you to communicate with the instrument.

ⓘ The advanced user can configure the Ethernet connection in any convenient way. The above procedure is given because it is known to work. The instrument will keep the assigned IP through the entire update process. However, when the update is complete, factory defaults are restored and the IP will be set to 192.168.1.5.

Loading Firmware

Start the firmware update by running the Cryo-con Firmware Utility. This launches a dialog box as shown here.

The instrument's default IP will appear in the dialog box. This can be changed if necessary.

Click the **Connect** button. The status box should update to indicate a connection, but the instrument display will not change.

Next, the firmware update file needs to be selected. Click on the browse button (. . .) to launch a file selection dialog.

Select the firmware hex file and click **Open**. The Firmware HEX file field will be updated with the file name. Also, the **Set Flash Mode** button will become active.

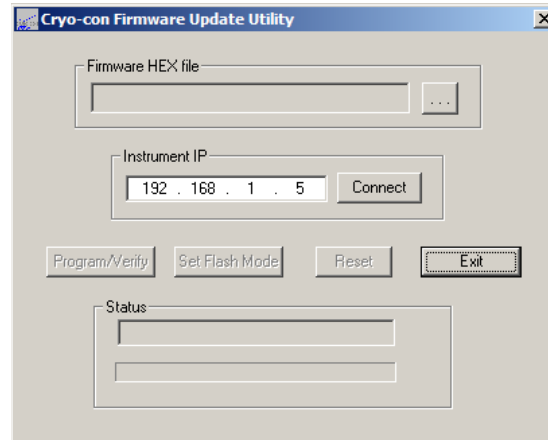

Caution: Once you click the **Set Flash Mode** button, the instrument will enter the firmware update mode and will not function normally again until the entire firmware update process is complete without error. Be sure you have the correct hex file before proceeding.

Click the **Set Flash Mode** button to set the instrument into the flash programming mode. The instrument will reset and start in the flash load mode. This is indicated by the display shown.

Since the instrument was reset, click **Connect** again to re-establish contact. This activates the **Program/Verify** button. The instrument will now display "Connected..."

```
Cryogenic Control Systems, Inc.
Boot Loader Waiting for connect.
IP:192.168.1.5      Port:5000 Rev:1.18D
```

Click the **Program/Verify** button to start the firmware download.

The last few lines of the instrument's display will indicate the status. First, the flash memories are erased and then individual records are programmed and verified.

There are about 6800 records in a typical file and the programming process takes about ten minutes.

When programming is complete, the unit will automatically reset and begin running the updated firmware. Factory defaults are also restored.

It is possible to power the instrument OFF during the programming process. This will require a re-start of the entire process after powering ON again. Once the download progress starts, the instrument powers-up in the boot loader mode and will not run the normal instrument firmware until the entire download process is completed without error.

If an error occurs, an error message will display on the instrument's front panel for 20 seconds and then an alert box will show on the PC.

Types of errors are: 1) Failure to erase flash memory. 2) Write error and 3) Verify error.

If the error persists after several programming attempts, there is a hardware problem and you will need to contact Cryo-con.

Appendix C: Troubleshooting Guide

Error Displays

Display	Condition
<div data-bbox="358 495 621 569" style="border: 1px solid black; padding: 5px; margin-bottom: 10px;"> · -----K </div> <p data-bbox="396 596 618 642">Or, an erratic display of temperature.</p>	<p data-bbox="691 485 1179 508">Input channel voltage measurement is out of range.</p> <p data-bbox="691 516 1219 539">Ensure that the sensor is connected and properly wired.</p> <p data-bbox="691 548 1321 594">Ensure that the polarity of the sensor connections is correct. Refer to the Sensor Connections section.</p> <p data-bbox="691 602 1300 722">Many sensors can be checked with a standard Ohmmeter. For resistor sensors, ensure that the resistance is correct by measuring across both the Sense and Excitation contacts. For a diode sensor, measure the forward and reverse resistance to ensure a diode-type function.</p>
<div data-bbox="358 747 621 821" style="border: 1px solid black; padding: 5px; margin-bottom: 10px;"> ·K </div>	<p data-bbox="691 737 1276 783">Input channel is within range, but measurement is outside the limits of the selected sensor's calibration curve.</p> <p data-bbox="691 791 1138 814">Check sensor connections as described above.</p> <p data-bbox="691 823 1279 869">Ensure that the proper sensor has been selected. Refer to the Input Channel Configuration Menu section.</p> <p data-bbox="691 877 1281 976">Change the sensor units to Volts or Ohms and ensure that the resulting measurement is within the selected calibration curve. Refer to the section on Input Channel Configuration Menu to display the calibration curve.</p>

Control Loop and Heater Problems

Symptom	Condition
Overtemp displayed.	The control loops were disengaged by detection of an excessive internal temperature. Possible causes: Shorted heater. Check heater resistance. Selection of a heater resistance that is much greater than the actual heater resistance. Refer to the Control Loop Setup menu section. Selection of an AC Power line voltage that is much less than the actual voltage. Refer to the Fuse Replacement and Voltage Selection section. Check that the instrument's fan is running and that the sides and rear panel allow easy air flow.
Readback displayed.	The control loops were disengaged by the heater current read-back monitor. Most likely cause is an open heater.
SensorFLT displayed.	The control loops were disengaged by a sensor fault condition. Correct the input sensor fault condition to proceed. The control loops will only engage when there is a valid temperature reading on their input. The exception is when a loop is assigned a control mode of Off or Manual.
OTDisconn displayed.	The control loops were disengaged by the Over Temperature Disconnect monitor. This was done to protect user equipment from damage due to overheating. To configure the monitor, refer to the System Functions Menu section.
The heater output current monitor is jumping up and down by about 1%	This is normal and does not indicate unstable heater power. The output current monitor is coarsely quantized and is displayed only for an indication of proper function.
The controller should be applying power, but the display is showing 0% output.	The output indicated on the display is the actual measured output power of the control loop. A reading of 0% while the controller is attempting to output power usually indicates an open heater.
Unstable control.	If the system is oscillating, try de-tuning the PID values by decreasing P, increasing I and setting D to zero. If the oscillations cannot be stopped by this procedure, the cause is likely that your system has an excessive time delay. Linear control algorithms, including PID, cannot control systems with excessive time delay. These problems often occur in systems that use heat pipes, or depend on gas flow between the heater and temperature sensor elements. The only solution to such systems is to re-design the equipment to reduce the time delay, or to externally implement a time delay compensation algorithm, such as a Smith Predictor. Do not try to control on Ohms or Volts. The controller will work correctly with either of these sensor units, but the PID values required are significantly different and most sensors are non-linear. Furtherer, there is no advantage to controlling in sensor units. Optimize the control loop parameters by using the Autotune feature described in the Autotuning section. Most cryogenic systems require significantly different PID parameters at different temperatures. To ensure stable control over a wide temperature range, use the PID Table feature described in the PID Table Entry section. If the heater is controlling with an output power level less than 10%, switch to the next lower heater range.

Symptom	Condition
Autotune indicates a status of 'Abort' or 'Fail'.	Autotune will only abort if the control loops are not engaged or there is an invalid temperature reading on the control input channel. If it cannot generate a solution because of issues in the system dynamics, it will indicate a status of 'Fail'.
Autotune times out and does not generate effective PID parameters.	<p>Extend the Display Filter time constant to reduce system level noise and try autotune again. The display filter is described in the System Functions Menu section. Systems using diode type sensors above 50K will usually require a 4 or 8 second time constant. This setting may be returned to any desired value once tuning is complete.</p> <p>Switch to the lowest possible heater range that will control at the target setpoint.</p> <p>Try autotuning in the PI- mode instead of PID. Most cryogenic systems do not benefit from the D term.</p> <p>If a Cryo-cooler is being used, set the controller's cryocooler filter to Input mode. This may be returned to Off or Cancel mode once tuning is complete.</p> <p>Experiment with the DeltaP parameter. Increasing it often improves autotune success.</p>

Temperature Measurement Errors

Symptom	Condition
Noise on temperature measurements.	<p>Possible causes:</p> <ol style="list-style-type: none"> Excessive noise pickup, especially AC power line noise. Check your wiring and shielding. Sensors must be floating, so check that there is no continuity between the sensor connection and ground. Review the System Shielding and Grounding Issues section. <p>Note: Cryo-con controllers use a shielding scheme that is slightly different than some other controllers. If you are using cable sets made for use with other controllers, some shield connections may need to change. If pin 3 of the input connector is connected to the cable shield, disconnect it and either re-connect the shield to the backshell contact or leave the shield floating. No connection should ever be made to pin 3 of the input connector.</p> <p>Check for shielding problems by temporarily removing the input connector's backshell. If the noise changes significantly, current is being carried by the shields and is being coupled into the controller.</p> <ol style="list-style-type: none"> Use a longer display filter time constant to reduce displayed noise.

Symptom	Condition
DC offset in temperature measurements.	<p>Possible causes:</p> <ol style="list-style-type: none"> 1. The wrong sensor type or sensor calibration curve is being used. Refer to the Input Channel Configuration Menu section. 2. DC offset in cryostat wiring. Review the Thermal EMF and AC Bias Issues section. Use AC bias, if necessary, to cancel the offset error. 3. A four-wire measurement is not being used. Some cryostats use a two-wire measurement internally. This can cause offset errors due to lead resistance. 4. Thermocouples: These sensors will often have DC offset errors. Use offset calibration procedure described in the section titled "Using Thermocouple Sensors".
No temperature reading.	Review the Error Displays section above.

Remote I/O problems

Symptom	Condition
Can't talk to RS-232 interface.	<p>Possible causes:</p> <ol style="list-style-type: none"> 1. Ensure that the baud rate of the controller matches that of the host computer. To check the controller's baud rate, press the System key and scroll down to the RIO-RS232 field. 2. Ensure that the host computer settings are 8-bits, No parity, one stop bit. 3. The RS-232 port does not have an effective hardware handshake method. Therefore, terminator characters must be used on all strings sent to the controller. Review the RS-232 Configuration section. 4. Ensure that you are using a Null-Modem type cable. There are many variations of RS-232 cables and only the Null-Modem cable will work with Cryo-con controllers. This cable is detailed in the RS-232 Connections section. <p>Debugging tip: Cryo-con utility software can be used to talk to the controller over the RS-232 port using the terminal mode. All command and response strings are displayed. This is a good way to establish a connection.</p>
Intermittent lockup on RS-232 interface.	<p>Possible causes:</p> <ol style="list-style-type: none"> 1. Long cables. Try using a lower baud rate. In some cases, inserting a 50mS delay between commands will help. 2. Noise pickup. Try using shielded cables with the shield connected to a metal backshell at both ends. 3. Don't send reset (RST) commands to the controller before reading.

Symptom	Condition
Can't talk to IEEE-488 option	<p>Possible causes:</p> <ol style="list-style-type: none"> 1. Ensure that the GPIB option is installed and the GPIB address is set in the System Menu. 2. Ensure that the EOI handshake is set. Please review the GPIB Configuration section. 3. Check that the controller's address matches the host computer's assignment. <p>Debugging tip: Cryo-con utility software can be used to talk to the controller over the IEEE-488 port using the terminal mode. All command and response strings are displayed. Since the software provides the proper interface setup, it is a good way to establish initial connection.</p>
Intermittent lockup on the IEEE-488 option.	<p>Possible causes:</p> <ol style="list-style-type: none"> 1. Bus cables too long or too many loads on a single bus. 2. Don't send reset commands before each query. This was common in early IEEE-488 systems. 3. Ground loops: Some equipment manufacturers improperly connect the IEEE-488 Shield Ground wire to their circuit board ground. This can cause ground loops with equipment that is properly connected. Debug by disconnecting instruments from the bus. 4. Use of unshielded bus cables.

Symptom	Condition
Can't talk to the LAN interface.	<p>Possible causes:</p> <ol style="list-style-type: none"> 1. The TCP settings between the monitor and the PC are incompatible. Review the network configuration section. 2. PC Client software not configured to use TCP Data Socket 5000. <p>Debugging tip: The Wireshark protocol analyzer is effective in diagnosing network connection problems. It is available at wireshark.org.</p>

General problems

Symptom	Condition
Controller periodically resets, or resets when Control key is pressed.	Generally caused by low AC line voltage. Check the AC voltage and ensure that it matches the instrument's voltage selection. AC line voltage selection is described in the Fuse Replacement and Voltage Selection section.
Complete failure.	Possible cause: <ol style="list-style-type: none"><li data-bbox="646 575 1278 646">1. Blown fuse. Check line voltage selection before installing new fuses. Review the Fuse Replacement and Voltage Selection section.<li data-bbox="646 657 1278 728">2. Rack mounted instruments: Screws were used in the rack mount shelf that are too long and have penetrated the internal circuit board of the controller.

Appendix D: Tuning Control Loops

Introduction

Tuning PID loops to maintain high accuracy control can be a laborious process since the time-constants in cryogenic systems are often long. Further, some systems must operate over a very wide range of temperature, requiring different PID settings at different setpoints.

The following is a guide to various methods of obtaining PID control loop coefficients.

Various methods for obtaining PID coefficients

The system provider

If your controller was received as part of a cryogenic system, the PID control loops should already be setup for optimum control. If the system operates over a wide range of temperature, it will use one of the available Table control modes where PID values are listed for different setpoints.

If the installed PID values do not provide stable control, you should contact the system manufacturer for assistance.

Taking PID values from a different controller

If the PID values required to control a system are known from a different type controller, these values may be useful.

The Proportional, or P term is a unit-less gain factor. There is no industry standard definition for it and, therefore, it can vary significantly from one manufacturer to another. If the P term does not work well when used directly, try a using the value divided by ten. For further assistance, please contact Cryo-con support.

The Integral, or I term is in units of Seconds and should be the same for different controllers. Note however that some manufacturers use a 'Reset' value instead of directly using an Integral term. In this case, the Integral term is just the inverse of the Reset value.

The Derivative, or D gain term is in units of inverse Seconds and should be the same for various controllers.

Using Factory Default PID values

Controllers are shipped from the factory with very conservative PID values. They will give stable control in a wide range of systems, but will have very slow response times.

Often, the factory values provide a good start for the autotune process. The values are: P 0.1, I 5.0 and D 0.0.

Autotuning

Autotuning is the easiest way to obtain PID values, or optimize existing ones. Please review the [Autotuning](#) section of this manual.

Manual Tuning

The final, and most laborious method of tuning a control loop is manual tuning. This involves generating values for P, I and D by observing the system's response to the stimulus of the heater output.

Various methods of manually tuning the controller are described below.

Manual Tuning Procedures

Manually tuning a PID control loop is relatively simple. It is greatly assisted by use of a data-logging program, such as the Cryo-con utility software package described in the Cryo-con Utility Software section.

Ziegler-Nichols Frequency Response Method

This method is based on the assumption that a critically damped system is optimal and the fact that stability and noise must be traded for response time. It requires driving your system into temperature oscillation. Care should be taken so that this oscillation does not cause damage.

Enable the Over Temperature Disconnect feature of the controller if there is concern over possible damage from overheating.

1. Enter a setpoint value that is a typical for the envisaged use of the system. Select a heater range that is safe for the equipment. Set initial PID values of Pgain=0.1, Igain=0 and Dgain=0.
2. Engage the control loops by pressing the **Control** key.
3. Increase the Pgain term until the system is just oscillating. Note the Pgain setting as the Ultimate Gain, K_c , and the period of oscillation as the Ultimate Period, T_c .
4. Set the PID values according to the following table:

Control Type	Pgain	Igain	Dgain
P only	$0.5 * K_c$	0	0
PI only	$0.4 * K_c$	$0.8 * T_c$	0
PID	$0.6 * K_c$	$0.5 * T_c$	$0.85 * T_c$

5. Wait for the system to stabilize. If the resultant heater power output reading is less than 10% of full scale, select the next lower heater range setting. A range change will not require re-tuning.

ⓘ Note: In systems where there is high thermal noise, including cryocoolers, a Dgain value of zero is often used. The Dterm is a derivative action, which can introduce additional noise into the control process.

Appendix E: Sensor Data**Cryo-con S700 Silicon Diode**

The Cryo-con S700 Silicon diode sensor with a 10 μ A excitation current.

	Volts	Temp (K)		Volts	Temp (K)		Volts	Temp (K)
1	0.1633	475.0000	41	0.6393	260.0000	81	1.2510	18.0000
2	0.1733	470.0000	42	0.6586	250.0000	82	1.2720	17.0000
3	0.1834	465.0000	43	0.6807	240.0000	83	1.2950	16.0000
4	0.1935	460.0000	44	0.7040	230.0000	84	1.3280	15.0000
5	0.2038	455.0000	45	0.7238	220.0000	85	1.3650	14.0000
6	0.2141	450.0000	46	0.7461	210.0000	86	1.4150	13.0000
7	0.2246	445.0000	47	0.7682	200.0000	87	1.4700	12.0000
8	0.2351	440.0000	48	0.7916	190.0000	88	1.5270	11.0000
9	0.2458	435.0000	49	0.8133	180.0000	89	1.5750	10.0000
10	0.2565	430.0000	50	0.8338	170.0000	90	1.5990	9.5000
11	0.2673	425.0000	51	0.8547	160.0000	91	1.6230	9.0000
12	0.2781	420.0000	52	0.8753	150.0000	92	1.6540	8.5000
13	0.2891	415.0000	53	0.8977	140.0000	93	1.6670	8.0000
14	0.3001	410.0000	54	0.9198	130.0000	94	1.6840	7.5000
15	0.3111	405.0000	55	0.9373	120.0000	95	1.7080	7.0000
16	0.3222	400.0000	56	0.9542	110.0000	96	1.7310	6.5000
17	0.3334	395.0000	57	0.9768	100.0000	97	1.7500	6.0000
18	0.3446	390.0000	58	0.9865	95.0000	98	1.7690	5.5000
19	0.3558	385.0000	59	0.9950	90.0000	99	1.7850	5.0000
20	0.3671	380.0000	60	1.0050	85.0000	100	1.7970	4.7500
21	0.3784	375.0000	61	1.0144	80.0000	101	1.8000	4.5000
22	0.3897	370.0000	62	1.0241	75.0000	102	1.8090	4.2500
23	0.4011	365.0000	63	1.0325	70.0000	103	1.8160	4.0000
24	0.4125	360.0000	64	1.0420	65.0000	104	1.8210	3.7500
25	0.4239	355.0000	65	1.0506	60.0000	105	1.8270	3.5000
26	0.4353	350.0000	66	1.0587	55.0000	106	1.8340	3.2500
27	0.4467	345.0000	67	1.0673	50.0000	107	1.8390	3.0000
28	0.4581	340.0000	68	1.0753	45.0000	108	1.8460	2.7500
29	0.4695	335.0000	69	1.0842	40.0000	109	1.8520	2.5000
30	0.4808	330.0000	70	1.0870	38.0000	110	1.8560	2.2500
31	0.4922	325.0000	71	1.0904	36.0000	111	1.8590	2.0000
32	0.5035	320.0000	72	1.0941	34.0000	112	1.8630	1.7500
33	0.5148	315.0000	73	1.0974	32.0000	113	1.8660	1.5000
34	0.5261	310.0000	74	1.1011	30.0000			
35	0.5373	305.0000	75	1.1054	28.0000			
36	0.5485	300.0000	76	1.1108	26.0000			
36	0.5596	295.0000	77	1.1238	24.0000			
38	0.5707	290.0000	78	1.1650	22.0000			
39	0.5900	280.0000	79	1.2070	20.0000			
40	0.6131	270.0000	80	1.2290	19.0000			

Cryo-con S900 Silicon DiodeThe Cryo-con S900 Silicon diode sensor with a 10 μ A excitation current.

Volts	Temp(K)	Volts	Temp(K)	Volts	Temp(K)
0.09077	500.00	0.86921	160.00	1.06858	52.00
0.09281	499.00	0.87959	155.00	1.07023	51.00
0.11153	490.00	0.88988	150.00	1.07188	50.00
0.13320	480.00	0.90008	145.00	1.07353	49.00
0.15565	470.00	0.91021	140.00	1.07517	48.00
0.17873	460.00	0.92022	135.00	1.07681	47.00
0.20231	450.00	0.93008	130.00	1.07844	46.00
0.22623	440.00	0.93976	125.00	1.08008	45.00
0.25016	430.00	0.94927	120.00	1.08171	44.00
0.27403	420.00	0.95867	115.00	1.08334	43.00
0.29785	410.00	0.96794	110.00	1.08497	42.00
0.32161	400.00	0.97710	105.00	1.08659	41.00
0.34532	390.00	0.98615	100.00	1.08821	40.00
0.34768	389.00	0.99510	95.00	1.08983	39.00
0.36898	380.00	1.00393	90.00	1.09145	38.00
0.39261	370.00	1.00569	89.00	1.09306	37.00
0.41620	360.00	1.00744	88.00	1.09468	36.00
0.43976	350.00	1.00918	87.00	1.09629	35.00
0.46330	340.00	1.01093	86.00	1.09791	34.00
0.48681	330.00	1.01267	85.00	1.09952	33.00
0.51024	320.00	1.01439	84.00	1.10124	32.00
0.52192	315.00	1.01612	83.00	1.10295	31.00
0.53356	310.00	1.01785	82.00	1.10465	30.00
0.54516	305.00	1.01957	81.00	1.10643	29.00
0.55674	300.00	1.02127	80.00	1.10828	28.00
0.56828	295.00	1.02299	79.00	1.10996	27.00
0.57980	290.00	1.02471	78.00	1.11217	26.00
0.59131	285.00	1.02642	77.00	1.11480	25.00
0.60279	280.00	1.02814	76.00	1.11828	24.00
0.61427	275.00	1.02985	75.00	1.12425	23.00
0.62573	270.00	1.03156	74.00	1.13841	22.00
0.63716	265.00	1.03327	73.00	1.16246	21.00
0.64855	260.00	1.03498	72.00	1.18193	20.00
0.65992	255.00	1.03669	71.00	1.19816	19.00
0.67124	250.00	1.03839	70.00	1.21325	18.00
0.68253	245.00	1.04010	69.00	1.22816	17.00
0.69379	240.00	1.04179	68.00	1.24342	16.00
0.70503	235.00	1.04349	67.00	1.25932	15.00
0.71624	230.00	1.04518	66.00	1.27621	14.00
0.72743	225.00	1.04687	65.00	1.29401	13.00
0.73861	220.00	1.04856	64.00	1.31277	12.00
0.74978	215.00	1.05024	63.00	1.33317	11.00
0.76094	210.00	1.05192	62.00	1.35568	10.00
0.77205	205.00	1.05360	61.00	1.37998	9.00
0.78311	200.00	1.05528	60.00	1.40827	8.00
0.79412	195.00	1.05696	59.00	1.44098	7.00
0.80508	190.00	1.05863	58.00	1.47740	6.00
0.81599	185.00	1.06029	57.00	1.51590	5.00
0.82680	180.00	1.06196	56.00	1.55483	4.00
0.83754	175.00	1.06362	55.00	1.59108	3.00
0.84818	170.00	1.06528	54.00	1.62255	2.00
0.85874	165.00	1.06693	53.00	1.64342	1.00

Cryo-con S950 Silicon Diode

The Cryo-con S950 Silicon diode sensor with a 10 μ A excitation current.

Temp(K)	Volts	Temp(K)	Volts	Temp(K)	Volts
370.00	0.392610	40.00	1.088210	11.50	1.327203
360.00	0.416200	39.00	1.089830	11.00	1.337854
350.00	0.439760	38.00	1.091450	10.50	1.349047
340.00	0.463300	37.00	1.093060	10.00	1.360897
330.00	0.486810	36.00	1.094680	9.50	1.373526
320.00	0.510240	35.00	1.096290	9.00	1.387055
310.00	0.533560	34.00	1.097910	8.50	1.401595
300.00	0.556740	33.00	1.099520	8.00	1.417234
290.00	0.579800	32.00	1.101240	7.50	1.434022
280.00	0.602790	31.00	1.102950	7.00	1.451961
270.00	0.625730	30.00	1.104650	6.80	1.459447
260.00	0.648550	29.00	1.106430	6.60	1.467099
250.00	0.671240	28.00	1.108280	6.40	1.474908
240.00	0.693790	27.00	1.109960	6.20	1.482860
230.00	0.716240	26.00	1.112170	6.00	1.490940
220.00	0.738610	25.00	1.114800	5.80	1.499128
210.00	0.760940	24.00	1.118280	5.60	1.507404
200.00	0.783110	23.00	1.124250	5.40	1.515741
190.00	0.805080	22.00	1.138410	5.20	1.524110
180.00	0.826880	21.00	1.162460	5.00	1.532477
170.00	0.848180	20.00	1.181930	4.80	1.540805
160.00	0.869210	19.50	1.190399	4.60	1.549103
150.00	0.889880	19.00	1.198550	4.40	1.557380
140.00	0.910210	18.50	1.206400	4.20	1.565604
130.00	0.930080	18.00	1.214061	4.00	1.573730
120.00	0.949270	17.50	1.221594	3.80	1.581750
110.00	0.967940	17.00	1.229179	3.60	1.589600
108.00	0.971610	16.50	1.236925	3.40	1.597250
107.00	0.973440	16.00	1.244891	3.20	1.604760
106.00	0.975270	15.50	1.253099	3.00	1.612101
100.00	0.986150	15.00	1.261547	2.80	1.619259
90.00	1.003930	14.50	1.270227	2.60	1.626214
80.00	1.021270	14.00	1.279123	2.40	1.632905
75.00	1.029850	13.50	1.288232	2.20	1.639304
70.00	1.038390	13.00	1.297560	2.00	1.645318
60.00	1.055280	12.50	1.307131	1.80	1.650844
50.00	1.071880	12.00	1.316990	1.60	1.655871
				1.40	1.660321

Sensor Packages

The SM and CP Sensor Packages

The S950-SM is mounted in a rugged surface-mounted package. This compact package features a low thermal mass and is easy to install.

Package material is gold plated OHFC copper on an Alumina substrate. Solder limits the temperature range to 400K.

Leads are 3 inches, material is 37 AWG copper with Polyimide insulation. Positive connection is Red and negative is Black.

Sensor is easily installed by attaching the substrate directly to the desired surface using cryogenic varnish. Leads should be thermally anchored.

The CP is an ultra-compact 'CP'. It features low thermal mass and operation to 500K.

Package material is gold plated OHFC copper.

Leads are 3 inches. Material is 37 AWG copper with Polyimide insulation. Positive connection is Red and negative is Black.

This package is extremely small and has a low thermal mass.

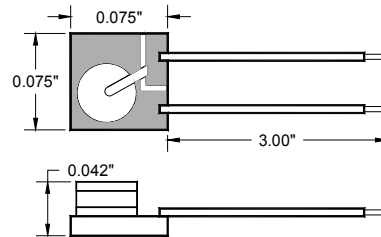
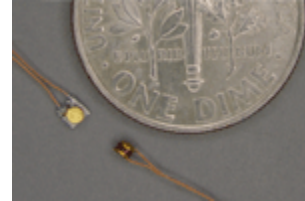

The BB Sensor Package

The BB package is an industry standard 0.310" bobbin package that features excellent thermal contact to the internal sensing element. This ensures a rapid thermal response and minimizes thermal gradients between the sensing element and the sensor package. Mechanical integrity of the sensor assures reliable performance even in severe applications.

With the bobbin package, the lead wires are thermally anchored to the sensor mounting. This is essential for accurate sensor readings.



Bobbin Package Specifications	
Bobbin Material	Gold plated Oxygen free hard Copper.
Marking	Individual serial number.
Sensor Bonding	Stycast® epoxy.
Mass	1.1g excluding leads.
Leads	36 inches, 36AWG Phosphor-Bronze. Four-lead color coded cryogenic ribbon cable. Insulation is heavy Formvar® .
Mounting	4-40 machine screw.
Temperature	400K Maximum.

Table 36: BB Package Specifications

Cable Color Codes	
V+	Clear
V-	Green
I+	Black
I-	Red

Table 37: Cable Color Code

Connections to the BB package are made using a color-coded four-wire, 36 AWG cryogenic ribbon cable.

Wires may be separated by dipping in Isopropyl Alcohol and then wiping clean.

Insulation is Formvarf and is difficult to strip. Techniques include use of a mechanical stripper, scrapping with a razor blade and passing the wire quickly over a low flame.

The BB package is easily mounted with a #4-40 brass screw. A brass screw is recommended because thermal stress will be reduced at cryogenic temperature.

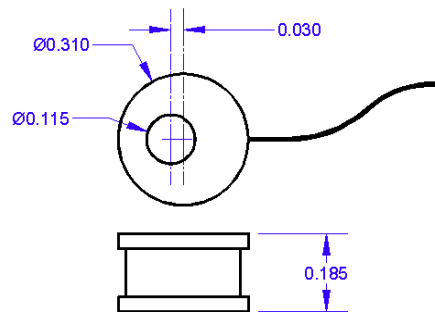

The mounting surface should be clean. A rinse with Isopropyl Alcohol is recommended.

First, apply a small amount of Apiezon N grease to the threads of the screw and on the mounting surface of the sensor package.

Next, place the bobbin on the mounting surface, insert screw through bobbin and lightly tighten.

Appendix F: Configuration Scripts

The Cryo-con Utility software package can be used to send configuration scripts to any Cryo-con instrument. These scripts consist mostly of standard remote commands and queries.

Scripts can be used to completely configure an instrument including setting custom sensor calibration curves and PID tables. They are commonly used in a manufacturing environment to set a baseline state for a target product. In the laboratory, scripts can be used to save and restore configurations for various experiments.

XML, or Extensible Markup Language, is used for the structure and format of script files. XML can be generated and edited with a standard text editor but advanced users may want to use one of the commonly available XML editors. Since it provides a structure and allows user documentation, it is easy to read and understand.

Configuration scripts have a file extension of .xml. These files are sent to an instrument by using the Operations->Send Command File function of the Cryo-con Utility Software.

Any remote command or query that is recognized by the instrument can be used in a script file. This includes commands that read and write user sensor calibration curves and PID tables. A complete description of available remote commands is given in the chapter titled [Remote Programming Guide](#). The Remote Command Tree section is particularly useful for the advanced user.

Script File Structure

Header and Footer

Like all XML files, script files have the following header and footer:

```
<?xml version="1.0"?>
<Transactions>
.
.
.
</Transactions>
```

All user supplied information is placed between the Transactions tags.

Basic XML Tags**Comment: <! >**

Inserts a comment in the file for documentation and readability. The comment within the angle brackets after the exclamation is ignored by the software.

```
<!Download User Curve 4>
<!------- Loop 1 ----->
```

Model: <Model> </Model>

Contains the Crycon instrument model number for source/destination verification.

```
<Model>Model 24C Version 2.03</Model>
```

Remote Command: <Command> </Command>

Send a remote command to the instrument. Commands can be any of the instrument's commands as described in the [Remote Programming Guide](#).

```
<Command>input c:sensor 2</Command>
<Command>LOOP 1:SOURCE A;Setpt 20.0</Command>
<Command>OVERTEMP:ENABLE ON</Command>
```

Query: <Query> </Query>

Query data from the instrument. Queries can be any of the instrument's commands as described in the [Remote Programming Guide](#). Query is generally used with a Response tag to compare the instrument's response to an expected value. If there is no Response tag, the result of the query is printed but not tested for errors.

```
<Query>input c:sensor?</Query>
<Query>input b:units K;units?</Query>
```

Response: <Response> </Response>

Identifies the expected response to a query. This tag must always follow a Query tag, otherwise, it is ignored. When the comparison fails, an error text message will be displayed and recorded to a file.

```
<Query>Relay? 1</Query>
<Response>Lo</Response>
<Query>input c:units?</Query>
<Response>K</Response> <! Should be Kelvin. Error if not >
```

Floating Point Response: <Floatresponse> <Floatresponse>

Compare the response returned from the instrument against an expected floating point number. This tag must always follow a Query tag; otherwise, it is ignored. When the comparison fails, an error text message will display. The returned value passes the test if within +/-2.5% of the expected value.

```
<Query>input a:ALAR:High?</Query>
<FloatResponse>200.000000</FloatResponse>
```

Pause: <Pause> </Pause>

Provide a pause for a specified number of milliseconds to allow the instrument to react to a command. Maximum 20 seconds. Generally, this is only used with the RS-232 serial interface where there is no hardware handshake.

```
<Pause>1000</Pause> <! Delay 1 second >
```

Group Tags

Any tag that is not defined is treated as a group tag. They are used to provide structure and enhance readability. Otherwise, they are ignored.

Complex Tags

Sending a user sensor calibration curve or a PID table to an instrument requires a complex tag because it can require many lines of data.

User Sensor Calibration Curve: <Calcur>

Send a sensor calibration curve to the instrument.

```
<!Download User curve 4>
<CalCur>Calcur 4</CalCur>
<!--Curve Name-->
<CalCur>My Sensor</CalCur>
<!--Curve Type-->
<CalCur>Diode</CalCur>
<!--Multiplier-->
<CalCur>-1.000000</CalCur>
<!--Units-->
<CalCur>Volts</CalCur>
<!--Curve Entries-->
<CalCur>0.163300 475.000000</CalCur>
<CalCur>0.173300 470.000000</CalCur>
<CalCur>0.183400 465.000000</CalCur>
<CalCur>1.866000 1.500000</CalCur>
<!--Send the end-of-transmission character-->
<CalCur>;</CalCur>
```

Transmission of the calibration curve starts with the first CALCUR tag and ends when the end-of-transmission character is sent. Comments are ignored.

Appendix G: Sensor Data Tables

Silicon Diode

Silicon diode sensors offer good sensitivity over a wide temperature range and are reasonably interchangeable.

Use in magnetic fields is not recommended.

Silicon diode sensors use a constant-current DC excitation of 10 μ A.

Cryo-con S900 Silicon Diode Name: Cryocon S900 Configuration: Diode		
T(K)	Volts	mV/K
1.4	1.63864	-36.56
4.2	1.53960	-33.91
10	1.35568	-26.04
20	1.18193	-11.34
30	1.10465	-3.12
50	1.07188	-1.46
77.35	1.02511	-1.69
100	0.98615	-1.85
150	0.88988	-2.03
200	0.78311	-2.17
250	0.67124	-2.28
300	0.55674	-2.36
355	0.42759	-2.33
400	0.32161	-2.38
450	0.20231	-2.37
500	0.09077	-2.12

Cryo-con S800 Silicon Diode Name: Cryocon S800 Configuration: Diode		
T(K)	Volts	mV/K
1.4	1.87515	-36.86
4.2	1.75099	-49.16
10	1.47130	-43.45
20	1.18867	-15.93
30	1.10594	-3.90
50	1.07079	-1.47
77.35	1.02356	-1.86
100	0.98170	-1.85
150	0.88365	-2.03
200	0.77887	-2.13
250	0.67067	-2.20
300	0.55955	-2.22
355	0.44124	-2.10
385	0.37611	-2.26

Scientific Instruments SI-430 and SI-440 Name: SI 430 Diode Configuration: Diode Name: SI 440 Diode Configuration: Diode		
T(K)	Volts	mV/K
1.4	1.63864	-36.56
4.2	1.53960	-33.91
10	1.36317	-26.04
20	1.17370	-11.34
30	1.10343	-3.12
50	1.07399	-1.46
77.35	1.02511	-1.69
100	0.98740	-1.85
150	0.89011	-2.03
200	0.78272	-2.17
250	0.67085	-2.28
300	0.55665	-2.36
355	0.42759	-2.33
400	0.32161	-2.38
450	0.20231	-2.37
500	0.09077	-2.12

Scientific Instruments SI-410		
Name: SI 410 Diode Configuration: Diode		
T(K)	Volts	mV/K
1.4	1.71488	-10.54
4.2	1.64660	-32.13
10	1.39562	-35.28
20	1.17592	-20.43
30	1.10136	-1.75
50	1.06957	-1.59
77.35	1.14905	-1.72
100	0.98322	-1.82
150	0.88603	-2.00
200	0.78059	-2.14
250	0.67023	-2.23
300	0.55672	-2.28
350	0.44105	-2.32
400	0.32319	-2.36
450	0.20429	-2.38

Lakeshore DT-470 Silicon Diode		
Name: LS DT-470 Configuration: Diode		
T(K)	Volts	mV/K
1.4	1.6981	-13.1
4.2	1.6260	-33.6
10	1.4201	-28.7
20	1.2144	-17.6
30	1.1070	-2.34
50	1.0705	-1.75
77.35	1.0203	-1.92
100	0.9755	-2.04
150	0.8687	-2.19
200	0.7555	-2.31
250	0.6384	-2.37
300	0.5189	-2.4
350	0.3978	-2.44
400	0.2746	-2.49
450	0.1499	-2.46
475	0.0906	-2.22

Lakeshore DT-670 Silicon Diode		
Name: LS DT-670 Configuration: Diode		
T(K)	Volts	mV/K
1.4	1.64429	-12.49
4.2	1.57848	-31.59
10	1.38373	-26.84
20	1.19775	-15.63
30	1.10624	-1.96
50	1.07310	-1.61
77.35	1.02759	-1.73
100	0.98697	-1.85
150	0.88911	-2.05
200	0.78372	-2.16
250	0.67346	-2.24
300	0.55964	-2.30
350	0.44337	-2.34
400	0.32584	-2.36
450	0.20676	-2.39
500	0.09068	-2.12

Platinum RTD

Platinum RTD sensors feature high stability, low magnetic field dependence and excellent interchangeability. They conform to the DIN43760 standard curve.

Platinum RTD, DIN43760 and IEC751		
Name: Pt100 385		Configuration: PTC100
Name: Pt1K 385		Configuration: PTC1K
T(K)	Ohms	Ω/K
20	2.2913	0.085
30	3.6596	0.191
50	9.3865	0.360
77.35	20.380	0.423
100	29.989	0.423
150	50.788	0.409
200	71.011	0.400
250	90.845	0.393
300	110.354	0.387
400	148.640	0.383
500	185.668	0.378
600	221.535	0.372
700	256.243	0.366
800	289.789	0.360
900	324.302	0.318
1123	390.47	0.293

Rhodium-Iron

Rhodium-Iron sensors feature high stability, low magnetic field dependence and reasonable interchangeability.

The Model 24C supports them with 1.0mA Constant-Current AC excitation.

Rhodium-Iron 27Ω		
Name: RhFe 27 1mA		Configuration: PTC100
T(K)	Ohms	Ω/K
1.4	1.5204	0.178
4.2	1.9577	0.135
10	2.5634	0.081
20	3.1632	0.046
30	3.5786	0.040
50	4.5902	0.064
77.4	6.8341	0.096
100	9.1375	0.106
150	14.463	0.105
200	19.641	0.102
250	24.686	0.101
300	29.697	0.101
350	34.731	0.101
400	39.824	0.103

Cryogenic Linear**Temperature Sensor (CLTS)**

CLTS sensors are inexpensive and offer excellent interchangeability. The Model 24C supports them with 100uA Constant-Current AC excitation.

CLTS-2B		
Name: CLTS		Configuration: CLTS
T(K)	Ohms	Ω/K
4.15	220	0.24
45	229.73	0.24
75	236.91	0.24
105	244.08	0.24
195	265.6	0.24
250	278.75	0.24
273.15	295.71	0.24
300	290.71	0.24

Cernox™

Cernox™ temperature sensors do not follow a standard calibration curve. Data shown here is for typical sensors.

The Model 24C supports Cernox™ using a 10mV or less Constant-Voltage AC excitation. Please refer to the section titled "[Voltage Bias Selection](#)"

Lakeshore Cernox™ CX-1010		
Name: User Supplied		Config: ACR 10mV Below 2.0K 3.0mV
T(K)	Ohms	Ω/K
0.1	21389	-558110
0.2	4401.6	-38756
0.3	2322.4	-10788
0.4	1604.7	-4765.9
0.5	1248.2	-2665.2
1	662.43	-514.88
1.4	518.97	-251.77
2	413.26	-124.05
3	328.95	-58.036
4.2	277.32	-32.209
6	234.44	-17.816
10	187.11	-8.063
20	138.79	-3.057
30	115.38	-1.819
40	100.32	-1.252
50	89.551	-0.929
77.35	70.837	-0.510
100	61.180	-0.358
150	47.782	-0.202
200	39.666	-0.130
250	34.236	-0.090
300	30.392	-0.065

Lakeshore Cernox™ CX-1030		
Name: User Supplied		Config: ACR 10mV Below 2.0K 3.0mV
T(K)	Ohms	Ω/K
0.3	31312	-357490
0.4	13507	-89651
0.5	7855.7	-34613
1	2355.1	-3265.2
1.4	1540.1	-1264.9
2	1058.4	-509.26
3	740.78	-199.11
4.2	574.20	-97.344
6	451.41	-48.174
10	331.67	-19.042
20	225.19	-6.258
30	179.12	-3.453
40	151.29	-2.249
50	132.34	-1.601
77.35	101.16	-0.820
100	85.940	-0.552
150	65.864	-0.295
200	54.228	-0.184
250	46.664	-0.124
300	41.420	-0.088
350	37.621	-0.065
400	34.779	-0.050
420	33.839	-0.045

Lakeshore Cernox™ CX-1050		
Name: User Supplied		Config: ACR 10mV
T(K)	Ohms	Ω/K
1.4	26566	-48449
2	11844	-11916
3	5733.4	-3042.4
4.2	3507.2	-1120.8
6	2252.9	-432.14
10	1313.5	-128.58
20	692.81	-30.871
30	482.88	-14.373
40	373.11	-8.392
50	305.19	-5.507
77.35	205.67	-2.412
100	162.81	-1.488
150	112.05	-0.693
200	85.800	-0.397
250	69.931	-0.253
300	59.467	-0.173
350	52.142	-0.124
400	46.782	-0.093
420	45.030	-0.089

Lakeshore Cernox™ CX-1080		
Name: User Supplied		Config: ACR 10mV
T(K)	Ohms	Ω/K
20	6157.5	-480.08
30	3319.7	-165.61
40	2167.6	-79.551
50	1565.3	-45.401
77.35	836.52	-15.398
100	581.14	-8.213
150	328.75	-3.057
200	220.93	-1.506
250	163.73	-0.863
300	129.39	-0.545
350	106.98	-0.368
400	91.463	-0.261
420	86.550	-0.231

Lakeshore Cernox™ CX-1070		
Name: User Supplied		Config: ACR 10mV
T(K)	Ohms	Ω/K
4.2	5979.4	-2225.3
6	3577.5	-794.30
10	1927.2	-214.11
20	938.93	-46.553
30	629.90	-20.613
40	474.89	-11.663
50	381.42	-7.490
77.35	248.66	-3.150
100	193.29	-1.899
150	129.60	-0.854
200	97.626	-0.477
250	78.723	-0.299
300	66.441	-0.201
350	57.955	-0.143
400	51.815	-0.106
420	49.819	-0.094

Ruthenium-Oxide

SI RO-600

The Scientific Instruments Inc. RO-600 is a Ruthenium-Oxide temperature sensor. Features include interchangeability and operation in high magnetic fields.

The Model 24C will support the RO-600 down to 1.0K.

Scientific Instruments RO-600		
Name: SI RO-600		Config: ACR 10mV
T(K)	Ohms	Ω/K
1	2327	-1203
1.4	1985	-660.6
2	1723	-343.5
3	1508	-152.4
4.2	1378	-80.4
6	1277	-40.9
10	1178	-15.4
20	1101	-4.08
30	1053	-4.0
40	1009	-3.5

Thermocouples

An external thermocouple module is required.

Thermocouple Type E		
Name: TC type E		Config: TC70
K	μV	$\mu V/K$
3.2	-9834.9	1.59
4.2	-9833	2.09
10	-9813.3	4.66
20	-9747	8.51
30	-9643.8	12.1
40	-9505.5	15.5
50	-9334.2	18.7
75	-8777.7	25.6
100	-8063.4	31.4
150	-6238.1	41.2
200	-3967.4	49.3
250	-1328.7	56
273.15	0	58.5
300	1608	61.1
350	4777.7	65.6
400	8159.8	69.6
500	15426	75.3
600	23138	78.6
670	28694	80
700	31100	80.4
800	39179	81
900	47256	80.4
1000	55247	79.3
1100	63119	78.1
1200	70842	76.3
1270	76136	75.2

Thermocouple Type K Name: TC type K Config: TC70		
K	μV	$\mu\text{V/K}$
3.2	-6457.7	0.74
4.2	-6456.9	0.92
10	-6448.5	2.01
10.5	-6447.4	2.12
20	-6417.8	4.15
30	-6365.1	6.39
40	-6290	8.61
50	-6193.3	10.7
75	-5862.9	15.6
100	-5417.6	19.9
150	-4225.5	27.5
200	-2692.8	33.5
250	-897.6	38
273.15	0	39.4
300	1075.3	40.6
350	3135.8	41.5
400	5200	40.8
500	9215.6	40.3
600	13325	41.7
670	16264	42.2
700	17533	42.4
800	21789	42.6
900	26045	42.4
1000	30251	41.7
1100	34373	40.7
1200	38396	39.7
1270	41153	39
1300	42318	38.7
1400	46131	37.5
1500	49813	36.1
1600	53343	34.5
1640	54712	34

Thermocouple Type T Name: TC type T Config: TC70		
K	μV	$\mu\text{V/K}$
3.2	-6257.5	1.03
4.2	-6256.2	1.4
10	-6242.9	3.12
20	-6199.2	5.58
30	-6131.3	7.99
40	-6040	10.2
50	-5927.7	12.2
75	-5573.6	16
100	-5131.2	19.4
150	-4004.3	25.6
200	-2575.3	31.4
250	-872.57	38
273.15	0	39.4
300	1067.4	40.8
350	3215.5	45
400	5560.2	48.7
500	10735	54.6
600	16437	59.2
670	20677	61.7

Thermocouple Type Chromel-AuFe(0.07%) Name: AuFe 0.07% Config: TC70		
K	μV	$\mu\text{V/K}$
1.2	-5299.6	8.98
2	-5292	10.1
4.2	-5266.8	12.6
10	-5181.8	16
30	-4846.4	16.6
40	-4681.5	16.5
75	-4084.6	17.8
100	-3627	18.8
150	-2645.2	20.4
200	-1600.1	21.4
250	-512.81	22
300	597.44	22.4
350	1696.3	21.8
400	2805.7	22.7
500	5135.3	23.4
600	7470.7	23.4

Appendix H: Rear Panel Connections

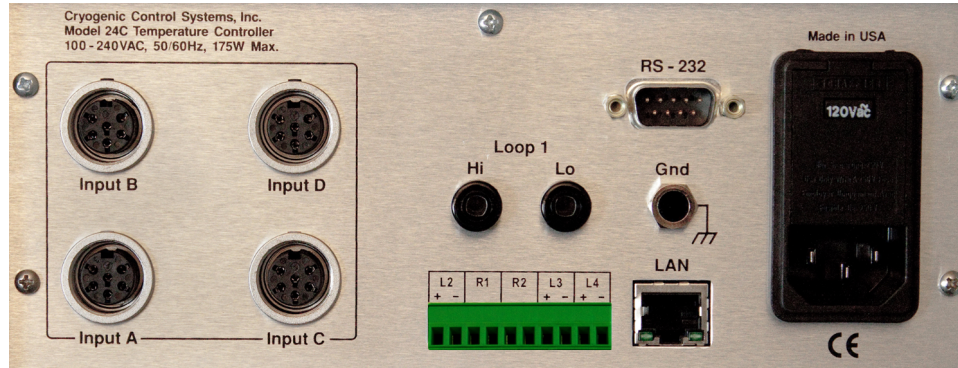

Figure 5: Model 24C Rear Panel Layout

AC Power Connection

The Model 24C requires single-phase AC power of 50 to 60 Hz. Voltages are set by the line voltage selector in the Power Entry Module on the rear panel. The power cord will be a standard detachable 3-prong type.

Line voltage selections are: 100, 120, 220 or 240VAC. Tolerance on voltages is +10% to -5% for specified accuracy and -10% for reduced full-scale heater output in the highest output range.

The power jack and mating plug of the power cable meet Underwriters Laboratories (UL) and International Electrotechnical Commission (IEC) safety standards.

User-replaceable fuses are incorporated in the Power Entry Module.

Note: The Model 24C uses a smart power on/off scheme. When the power button on the front panel is pressed to turn the unit off, the instrument's setup is copied to flash memory and restored on the next power up. If the front panel button is not used to toggle power to the instrument, the user should configure it and cycle power from the front panel button one time. This will ensure that the proper setup is restored when AC power is applied.



Caution: Protective Ground: To minimize shock hazard, the instrument is equipped with a three-conductor AC power cable. Plug the power cable into an approved three-contact electrical outlet or use a three-contact adapter with the grounding wire (green) firmly connected to an electrical ground (safety ground) at the power outlet.

Fuse Replacement and Voltage Selection

Access to the Model 24C's fuses and voltage selector switch is made by using a screwdriver to open fuse drawer in the power entry module. A slot is provided above the voltage selector window for this purpose.

The fuse and voltage selection drawer cannot be opened while the AC power cord is connected.

Voltage selection is performed by rotating the selector cams until the desired voltage shows through the window shown.

There are two fuses that may be removed by pulling out the fuse modules below the voltage selector. Fuses are specified according to the AC power line voltage used.

Line Voltage	Fuse	Example
100VAC, 120VAC	2.0A slow-blow	Littlefuse 313 002
220VAC, 240VAC	1.0A slow-blow	Littlefuse 313 001

Table 38. AC Power Line Fuses



Caution: Be sure to use the proper fuse for the selected line voltage. Use of an incorrect fuse can cause serious damage to the instrument.

Sensor Connections

All sensor connections are made at the rear panel of the Model 24C using the two DIN-6 receptacles provided.

Silicon diode and all resistor type sensors should be connected to the Model 24C using the four-wire method. It is strongly recommended that sensors be connected using shielded, twisted pair wire. Wires are connected as shown below and the shield should be connected to the metal back-shell of the connector.

The replacement part is an Amphenol T3400 001 and is available from Digikey.com.

Pin	Function
1	Excitation (-), I-
2	Sense (-), V-
3	Aux Power: +5VDC @ 500mA
4	Sense (+), V+
5	Excitation (+), I+
6	Not Connected

Table 39: Input Connector Pin-out

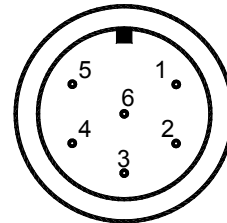

Rear View



Caution: To ensure proper low noise operation, cable shields should be connected to the metal back-shell of the connector. A metal clip is provided with the connector for this purpose. Please refer to the section on shielding and grounding for further information.

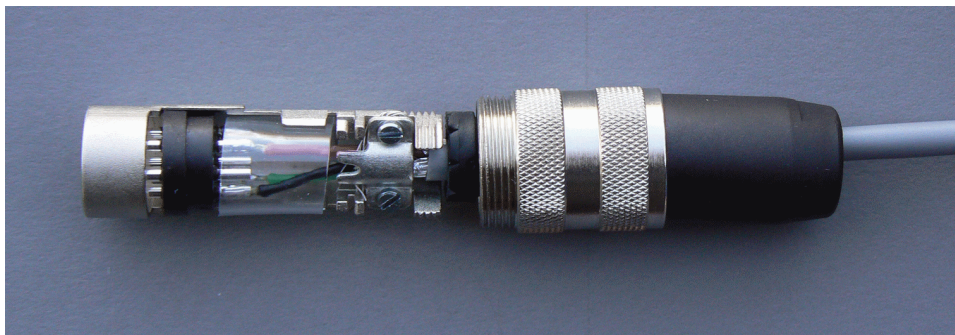

Figure 6: Proper Assembly of the Input Connector



Caution: Any disconnected inputs to the Model 24C should be configured to a sensor type of 'None'. This will turn the input off and prevent the high-impedance pre-amplifiers from drifting.

Recommended color codes for a sensor cable are as follows:

Color Code	Signal	Pin
White	Excitation(+)	5
Green	Excitation(-)	1
Red	Sense(+)	4
Black	Sense(-)	2

Table 40: Sensor Cable Color Codes

The cable used is Belden 8723. This is a dual twisted pair cable with individual shields and a drain wire. The shields and drain wire are connected to the connector's metal backshell in order to complete the shielding connection.

A four-wire connection is recommended in order to eliminate errors due to lead resistance. This is especially important for low resistance sensors including Platinum RTDs. Proper connection to diode and resistor type sensors is diagrammed below:

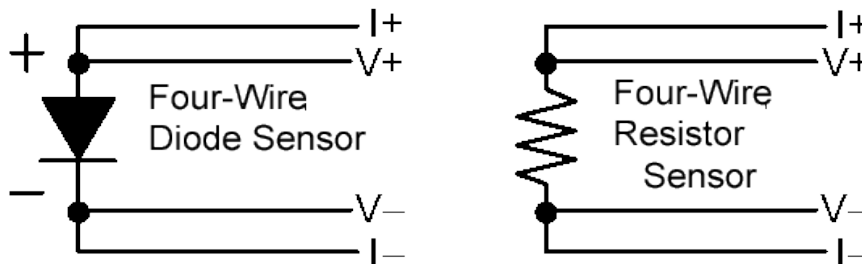

Figure 7: Diode and Resistor Sensor Connections

Control Loop #1 Connections

Rear panel Primary Heater Output (Loop #1) connections are made using a two-pin banana-plug on the rear panel. The replacement part is a Mueller Electric BU-00247-0 and is available from Digikey.com.

Pin	Function
Hi	Heater Output High
Lo	Heater Output Low
EGND	Earth-Ground (Chassis)

Table 41: Loop 1 Connections



Caution: The Model 24C has an automatic control-on-power-up feature. If enabled, the controller will automatically begin controlling temperature whenever AC power is applied. For a complete description of this function, please see the Auto-Ctl function in the [System Functions menu](#) section.

Control Loop #2 and Relay Connections

Connection to the Loop #2 Output is made on the rear panel using the 10-pin, 3.5mm detachable terminal block provided. The replacement part number is OSTTJ1011530 and is available and from digikey.com.

Pin	Function
1	Loop #2 Heater Output High
2	Loop #2 Heater Output Low
3	Relay #1 N.O.
4	Relay #1 Common.
5	Relay #2 N.O.
6	Relay #2 Common.
7	Loop #3 output High
8	Loop #3 output Low
9	Loop #4 output High
10	Loop #4 output Low

Table 42: Loop #2, #3, #4 and Relay Connections

Ethernet (LAN) Connection

The Ethernet connection on the Model 24C is a standard RJ-45 connector with two status LEDs. The left most LED indicates that a valid connection has been made to a hub or computer and the right most LED indicates activity on the LAN.

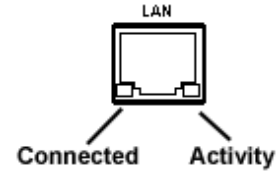

IEEE-488.2 Connections

The optional IEEE-488.2 (GPIB) connection is installed by connecting the dongle to the Ethernet port using a LAN cable. The interface will be configured by the instrument and will appear to your system as a standard IEEE-488.2 device.

RS-232 Connections

The Model 24C uses a Female DB-9 connector for RS-232 serial communications. The pin-out of this connector is as follows:

Pin	Function	Pin	Function
1	NC	6	NC
2	RXD, Receive data	7	NC
3	TXD, Transmit data	8	NC
4	NC	9	NC
5	Ground		

Table 43: RS-232 DB-9 Connector Pinout

The cable used to connect the Model 24C to a computer serial port is a Dual Female Null Modem cable. An example is Digikey Inc. part number AE1033-ND.

Index

AC power.....		OTD.....	35
Connection.....	147	Output power limit.....	30
Cord.....	7	Pgain.....	29, 30
Frequency.....	34	PID configuration.....	30
Fuse replacement.....	148	PID Table.....	31, 98
Low voltage.....	126	Pman.....	29, 30
Protective Ground.....	147	Proportional gain.....	30, 99
Smart on/off.....	19	Ramping.....	31, 59
Voltage Selection.....	148	Algorithm.....	59
Alarms.....	62	Operation.....	59
Ambient temperature.....	62	Setup.....	59
Audio.....	62	Ranges.....	30, 38
Clearing.....	26, 62	Read-back.....	16
Conditions.....	28	Setpoint.....	22, 29, 39, 98
Deadband.....	62	Setpoint.....	30
High setpoint.....	27	Setpoint entry.....	26
Latched.....	28, 62	Source selection.....	30
Setpoint.....	27	Table control mode.....	31, 38
Setup.....	28	Table index selection.....	31
Status.....	20	Temperature ramp.....	99
Viewing.....	26	Tuning.....	127
Auto Control Mode.....	34	Control stability.....	12
Autotuning.....		Control Types.....	
Modes.....	55	Man.....	13
Pre-tuning.....	55	Off.....	13
Setup.....	56	PID.....	13
Bridge Lock Indicator.....	45, 46	RampP.....	13
CALCUR commands.....	104	RampT.....	13
CalGen.....	9, 13, 27, 64	Table.....	13
Configuration Scripts.....	135	Data Logging.....	
XML.....	135, 136	Buffer.....	35
Control loop.....		Clearing.....	108
Autotuning.....	54, 127	Count.....	108
Control type selection.....	30	Format.....	108
Control types.....	98	Interval.....	108
Derivative gain.....	30	Reading.....	108
Dgain.....	29, 30	State.....	108
Differentiator gain term.....	99	Debugging Tips.....	83
Fault alarm.....	17	Display.....	
Heater read-back.....	100	Resolution.....	34, 94
Igain.....	29, 30	Time-constant.....	33
Integrator gain term.....	99	Displays.....	
Load.....	31	Bridge Lock Indicator.....	24
Load resistance selection.....	31	Control Loop Setpoint.....	25
Manual control mode.....	30	Home status display.....	23
Manual tuning.....	128	Input Channel Statistics.....	25
Maximum output.....	30, 99, 100	Loop Status Display.....	23
Maximum setpoint.....	31	Raw Input Measurement.....	25

Sensor fault.....	24	Statistics.....	
Temperature Display.....	24	Input statistics.....	28
Enclosure.....		Temperature history.....	28
Specifications.....	17	Variance.....	28
Ethernet.....		----K display.....	24
Connection.....	152K display.....	24
Factory Defaults.....	74	INPUT commands.....	95
Gateway.....	37	Input Performance.....	10
HTTP.....	74	ACR.....	11
IP.....	37	Diode.....	10
LabView™.....	2, 75	PTC100.....	10
Patch cable.....	74	PTC1K.....	10
SMTP.....	74	Input Protection.....	17
Subnet mask.....	37	Instrument Calibration.....	
TCP/IP.....	37, 74	Calibration Interval.....	73
TIMEP.....	74	Calibration Services.....	73
UDP.....	37, 74	Procedure.....	73
Factory Defaults.....	70	Keypad.....	
Restoring.....	70	Remote LED.....	92
Firmware.....		LabView™ drivers.....	6
Updates.....	6	LCD display.....	19
Firmware.....		Loop #1.....	
Revision level.....	6	Connection.....	151
Firmware Update Utility.....		Connector.....	7
FWutility.exe.....	117	Load resistance.....	14, 15
Introduction.....	117	Setup.....	29
Front Panel.....		LOOP commands.....	98
AC power key.....	22	Loop Status.....	
Alarm LED.....	22	Bar chart.....	23
ChA key.....	22	Fan Fault.....	16
Control LED.....	22	Htr-Low-R.....	16
Enumeration fields.....	21	OTDisconn.....	16
Keypad keys.....	21	-Htr Off-.....	16
Remote LED.....	22	-Overtemp-.....	16
Grounding, ground loop.....	71	-Readback-.....	16
Hardware Revision Level.....	6	Loops #3 and #4.....	
Home Status Display.....	23	Booster Supply.....	63
IEEE-488.....		External Supply.....	63
Address.....	92	Over Temperature Disconnect.....	
Configuration.....	75	Enable.....	35
Connection.....	152	OVERTEMP commands.....	102
GPIB.....	75	Setpoint.....	35
Input Channel.....		Source.....	35
Alarm enable.....	96	PID Table.....	38
Alarm outputs.....	17	Menu.....	38
Alarm status.....	96	Zone table.....	38
Audible alarm.....	17	Zones.....	38
Connector.....	7	PID Table Format.....	52
Display resolution.....	24	Relay.....	
Sensor units.....	95	Connector.....	7

Control mode.....	48	TC.....	40
DEAdband.....	89, 103, 104	Type selection.....	40
Fail-safe function.....	48	Sensor Calibration Curve.....	
Specifications.....	17	CRV file.....	49, 50
Status indicators.....	47	File format.....	104
RS-232.....		LogOhms.....	116
Configuration.....	75	Shielding RFI.....	71
Connection.....	152	Temperature Sensors.....	
S700.....		Cernox™.....	142, 143
Color Codes.....	133	CLTS.....	141
Mounting.....	133	Negative temperature coefficient.....	40
SCPI.....		Ruthenium-Oxide.....	144
Introduction.....	78	S900.....	139
Overview.....	77	S950.....	8
Sensor.....		Silicon diode.....	139
Calibration curve.....	40, 104	Thermocouple.....	5, 12, 67, 69, 144
Connection.....	17, 121, 149	Unit Name.....	93
Multiplier field.....	40	User Calibration Curves.....	1
Setup menu.....	40	User Configurations.....	20, 32
Table index.....	40	Utility software.....	6, 9